

Theme 13: Mechanisation of a dairy farm

FARM TOOLS AND EQUIPMENT (Level 2)

Topic	Training & information Content
13.1	Farm tools and equipment
13.2	SOP of farm machinery
13.3	Maintenance of farm machinery and equipment



1. You will learn about (learning objectives):

- Types of farm tools and equipment.
- Purposes of these tools and equipment.



2. Background

- The tools and equipment required depending on the level of mechanization desired and the scale of operation.
- However, some tools and equipment are essentially required such as the chaff cutter machine, milking pails, milk cans, digging hoes, machete (panga) back spay, etc.
- On farms maintaining more than 20 dairy cows, machine milking may be economical and more convenient as compared to hand milking.



2.1. Background Cont'd...

- Dairy farms with 50 or more cows may also require a milk cooler, electricity generator set, and a utility vehicle for the procurement of farm supplies and marketing of produce.
- These farms may require a tractor with implements for the cultivation of fodder crops and pasture management and maintenance, harvesting, transportation and conservation, and feeding etc.

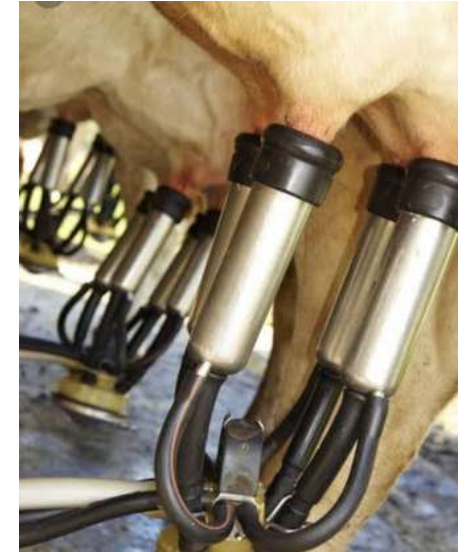

3. Introduction

- A well functioning dairy farm requires to have essential tools and equipment to run smoothly.
- There are several other modules that have discussed some of the farm machines, equipment, and tools. In this module, we will cover tools and equipment used in small scale farms and mention some advanced farm equipment at the end.
- Below are some of the modules you can go through that have covered some of the dairy farm tools and equipment in detail;
 - 1.10. Operating farm equipment and self-propelled tractors,
 - 1.11. Mechanization of feeding management,
 - Theme 7. Milk machines and handling (10 modules).

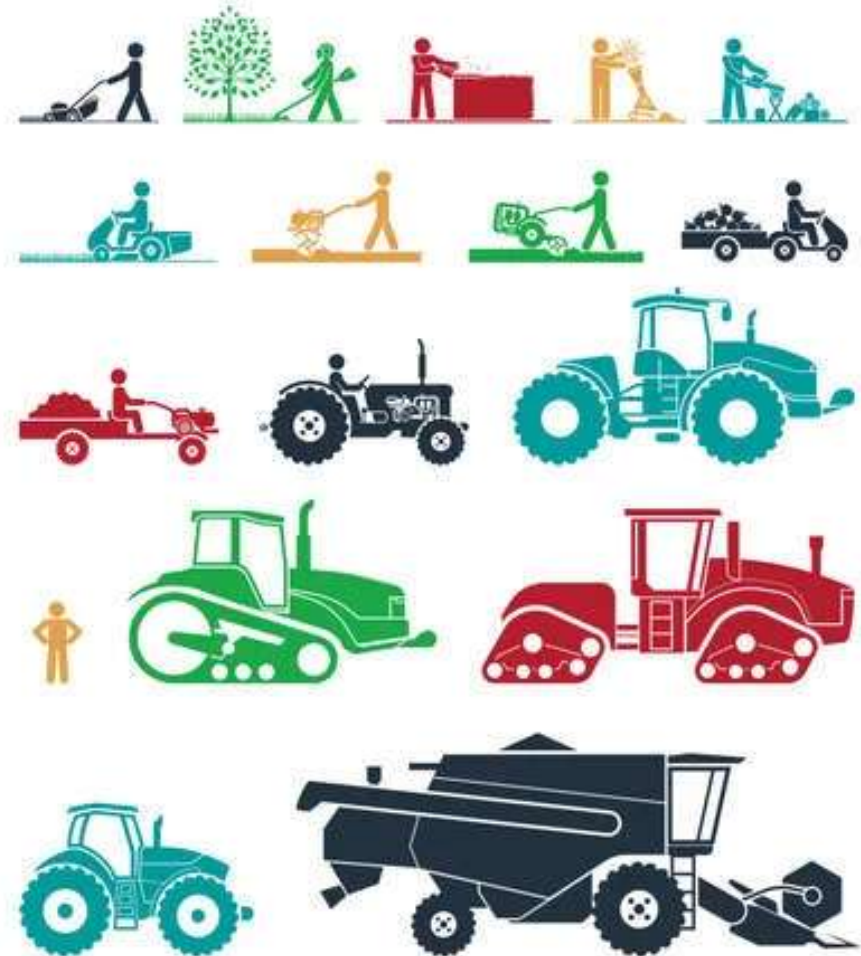

4. Farm tools and equipment categories

- Farm tools and equipment can be classified into several categories as follows;
 - 1) Manual tools and equipment.
 - 2) Structures and restraining tools.
 - 3) Animal related tools
 - 4) Milk and milking equipment and tools,
 - 5) Feed and fodder chopping, grinding/crushing, mixing, and pelleting tools.
 - 6) Fodder establishment, harvesting, and conservation,
 - 7) Farm office management tools,



5. Manual tools and equipment

- The picture attached represents most of the tools that are used by workers in a dairy farm. Some of their functions are shared below;

1. Wheelbarrow: carry things from one point to another for example feeds to cows.
2. Watering can: sprinkle liquid such as water, or a solution of molasses. For example during silage making process molasses and water solutions can be sprinkled evenly using this can.
3. Rake: scooping, scraping, gathering, or leveling materials, such as soil, mulch, or leaves e.g. even cow bedding such as sand,



5.1 Manual tools and equipment Cont'd...

4. Sickle: used to harvest forage for cows.
5. Pick Mattock: used for digging, prying, and chopping.
6. Machete: e.g. can be used to cut and chop forage,



5.2 Manual tools and equipment Cont'd...

7. Sprinkler: for irrigating forage,
8. Iron fork hoe: to loosen the soil, prior to planting or sowing.
9. Hammer: can be used to place nails or pull them out, e.g. make or repair fences etc.



7



Iron Fork Hoe

8



Hammers

9

5.3 Manual tools and equipment Cont'd...

10. Digging shovel: digging up, breaking apart, and lifting soil as well as scooping and moving loose materials,
11. Head pan: Used to help with holding water or solution.
12. Spade fork: or loosening, lifting, and turning for example hay.



10

Digging Shovel



11

Head pan



12

Spade Fork

5.4 Manual tools and equipment Cont'd...

- 13. Steel hoe: tilling (mixing) the soil or breaking the ground to loosen it,
- 14. Slasher: clearing thin and dense low-lying bush or scrub,
- 15. Spade: cutting into sod, edging, or digging trenches or anything that requires a sharp, straight edge.



5.5 Manual tools and equipment Cont'd...

16. Back sprayer; carry on the back and use hand to pump and another hand to spray cows or surfaces.

17. Foot sprayer; use foot to pump solution to spray

18. Weighing bands; Measure the weight of your cows.



6. Structure and restraining

- The dairy farms' structure and equipment have further been discussed under module, **8.1. Farms structures & housing for cows, calves, and youngstock.**
- The fences are used to restrain cows in a selected region of a farm. In extensive and semi-extensive systems (paddock grazing systems) there are types of simple fences that are used as shown;
 - i. Permanent physical fencing is typically for long-term use, so plan the location carefully before building. It consists of enough material, which is sufficiently strong enough to prevent and discourage animals from breaking through.
 - Materials used for this kind of fencing are barbed wire and wooden poles.



7. Tools and equipment for fencing

- 1. Wooden pole,
- 2. Barbed wire,
- 3. Hammer,
- 4. Wire strainer; help in tightening the barbed wire.
- 5. Nails (U shaped)
- 6. Pliers; cut wire,
- 7. Digging bars, dig holes to place wooden poles.



7.1 Electric fencing

- There are other type of fencing systems that can be used in advance on a paddocking grazing system. There are;
 - ii. Electric fencing that is placed on wooden poles and is permanent on the ground.
 - ii. The mobile electric fencing is temporary fencing that is easy to move.



7.2 Electric fencing tools and equipment's

- The tools for movable electric fence consists;
 - a) Easy to move poles(wooden or metal)
 - b) Suitable electric fencing wires,
 - c) Mobile energizer and
 - d) Solar panel.

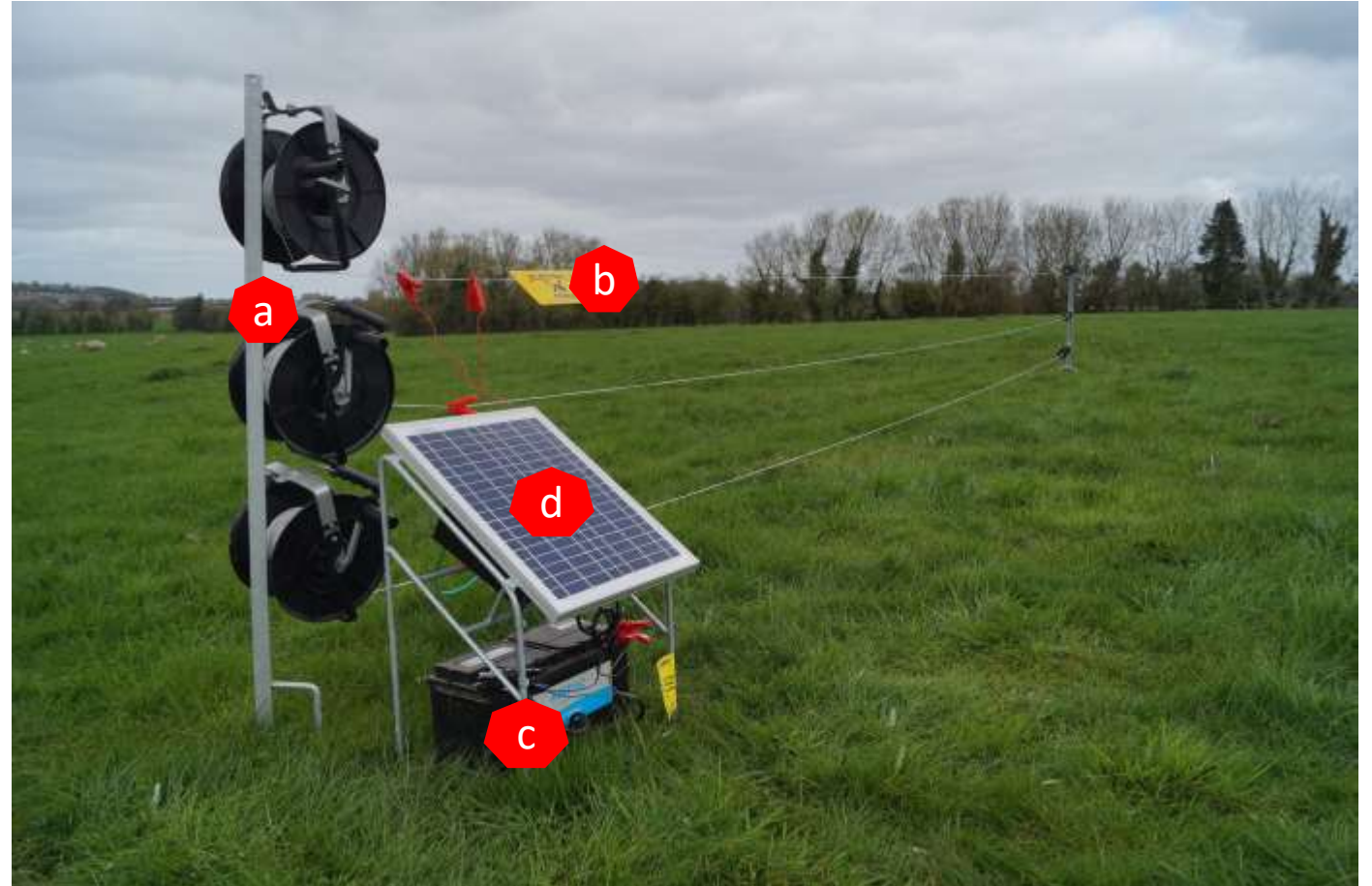

8. Animal related tools and equipment

- In a dairy farm there are several tools and equipment that are used on the cow, these are;

1. Medicine and vaccine administer tools.

- Needle,
- Syringe,
- Treatment gun; (i, ii, iii) all three can be used for administering the drug through the skin.
- Drench syringe and gun: Administers drug through the mouth.

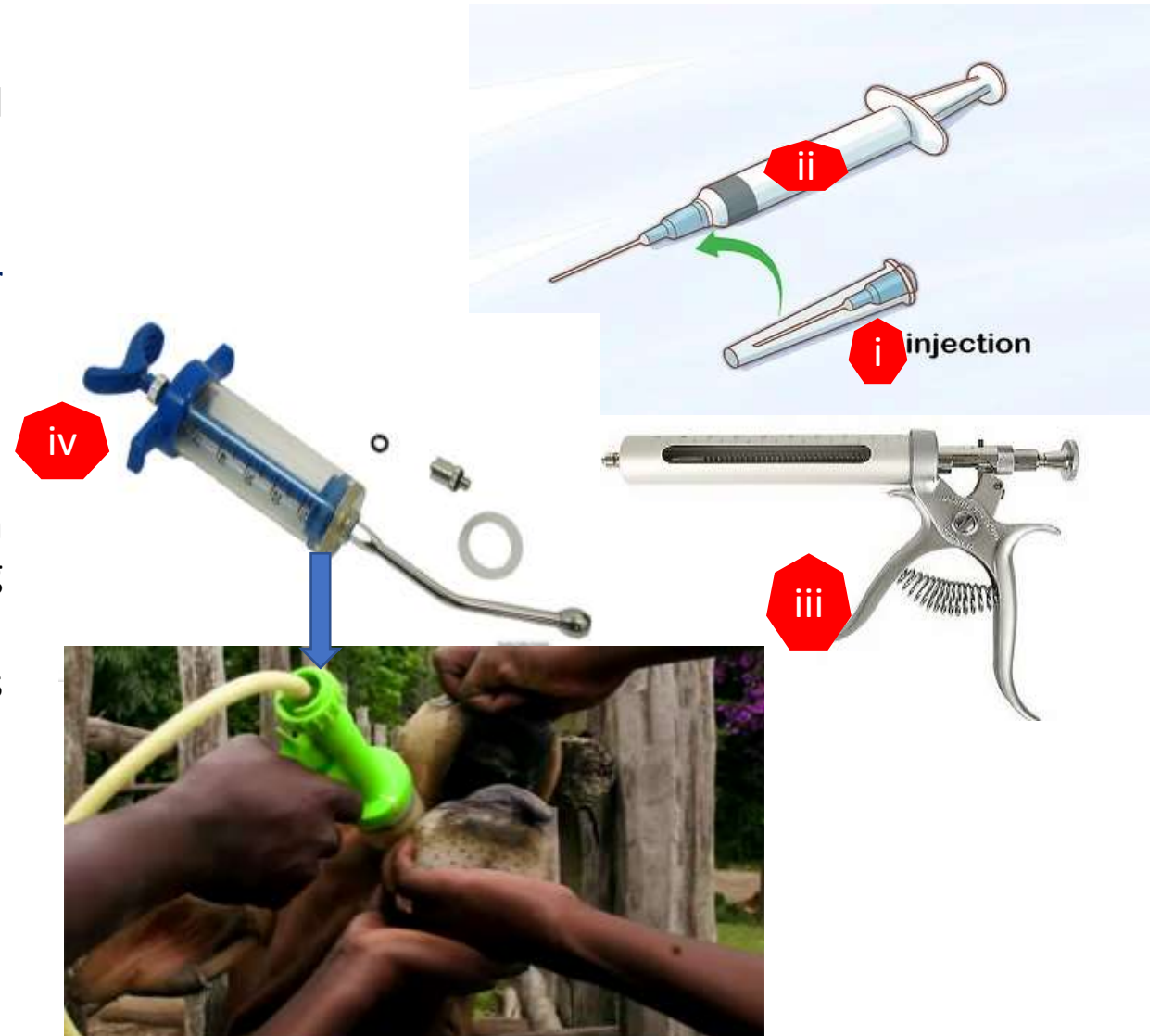

8.1 Animal related tools and equipment Cont'd: Hoof care tools for hoof trimming

- i. Hoof pick; pick dirt or object stuck on the hooves,
- ii. Hoof knives; trim hoof by slicing bit by bit,
- iii. Hoof nippers; trim by clipping hoof,
- iv. Hoof rasp (file); for filing the hooves to make a smooth finish.



8.2 Animal related tools and equipment's Cont'd: Identification tools

- i. Ear tags
- ii. Ear tag applicator



9. Milking tools and equipment categories

- These are any kind of machine, equipment, and tools for the purpose of milking, storing, preserving, and transporting milk.
- We will just mention a few here because this category was covered under theme **7. Milk machines and handling (module 1-10)**
- The common production processes are hand milking (use buckets or pails picture labeled 1) and machine milking (vacuum buckets milking picture labeled 2).

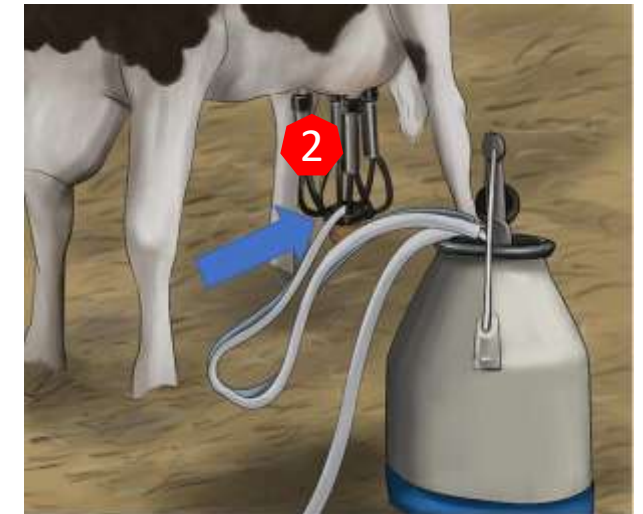

10. Tools and equipment's used during the milking process

1. Water pipes, cleaning brushes, and clothes/towels; for cleaning the cow, cow's udder, and equipment.
2. Udder cleaning and drying clothes/towels or disposables.
3. Udder clipping (shaving) makes it a lot easier to clean the udder.
4. Teat dip for prep and post dipping; used to disinfect the teats before and after milking.

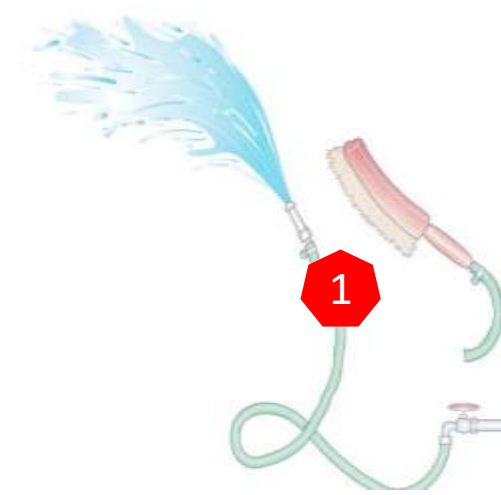

10.1 Tools and equipment's used during the milking process Cont'd...

- For mastitis check before milking, the following tools could be used;

5. Strip cup; for clinical mastitis check,

6. California mastitis test (CMT) kit; both clinical and subclinical mastitis check.

- More details on module **9.8. California Mastitis test**

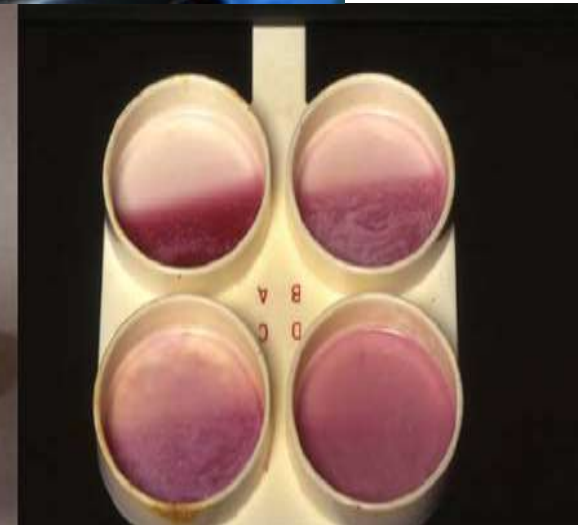

10.2 Tools and equipment's used during the milking process Cont'd...

- For milk storage and during milking in the parlour the following tools and equipment are used;

7. Milking buckets/pails for hand milking,
8. Milk sieves and sieving clothes are used to filter milk after milking.
9. Milk cans for the temporary storage of milk.



10.3 Tools and equipment's used during the milking process Cont'd...

- After milking a farmer should measure the milk and record the milk quantity per cow. The following tools are used;

10. Weighing scale; weighing the amount of milk in kilograms,

11. Weighing jugs; weighing the amount of milk in liters using volume.

12. Recording milk; using pen and paper for record-



11. Feed and fodder chopping, grinding/crushing, mixing, and pelleting tools

- Fodder (forage) chopping tools and equipment after harvesting are;
 - i. Chaff Cutter; It is a machine used for cutting fodder. Can be manually operated, animal operated and power operated chaff cutters.
 - ii. Chopper; to cut the straw or hay into small pieces to mix it together and feed to cows which is power operated.
- These are equipment used for smallholder farms. For large farmers, a bigger chopper machine is recommended.



11.1 Feed and fodder chopping, grinding/crushing, mixing, and pelleting tools Cont'd...

- Feed and fodder mixing and serving tools and equipment are;
 - iii. A cereals grinding machine; used to grind and crush seeds to smaller particles that the cow can digest.
 - iv. Total mixed ration (TMR) mixer; the machine is used to mix the fodder and feeds thoroughly to make a uniform mix before serving it to the cows.
- These are small and simple tools used in small-scale dairy farms, however, bigger machines can be found in the market.



12. Tools and equipment in more advanced farms

- The dairy farm tools and equipment mentioned in the slides above are the most common that can be found in small-scale farms.
- The slides that follow will mention some examples of tools and equipment that can be on dairy farms that are more advanced and or large-scale farms. For example using machine milking in place of hand milking, transporting manure using trailers mounted on a tractor in place of wheelbarrows, etc.

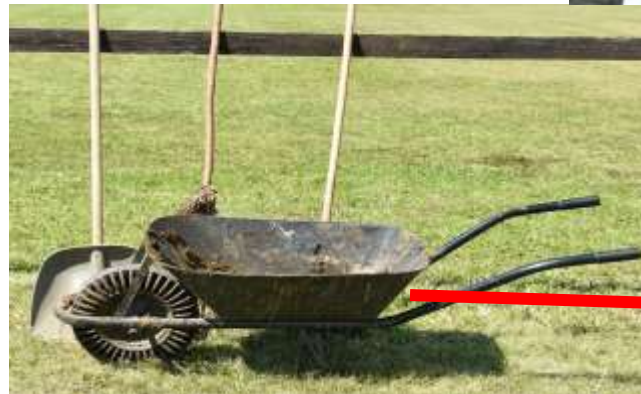

12.1 Tools and equipment in more advanced farms Cont'd: Milk machine with buckets

- Machines and tools for milking have been further discussed under topic 7. Milk machines and handling.
- Just a brief view of advanced or automated machine milking in the two slides. For example, a bucket milking machine system is as shown below. Milk from the cow is channeled through long milk tubes to a milk bucket and then transferred to milk cans after weighing. Blue arrow shows milk flow.

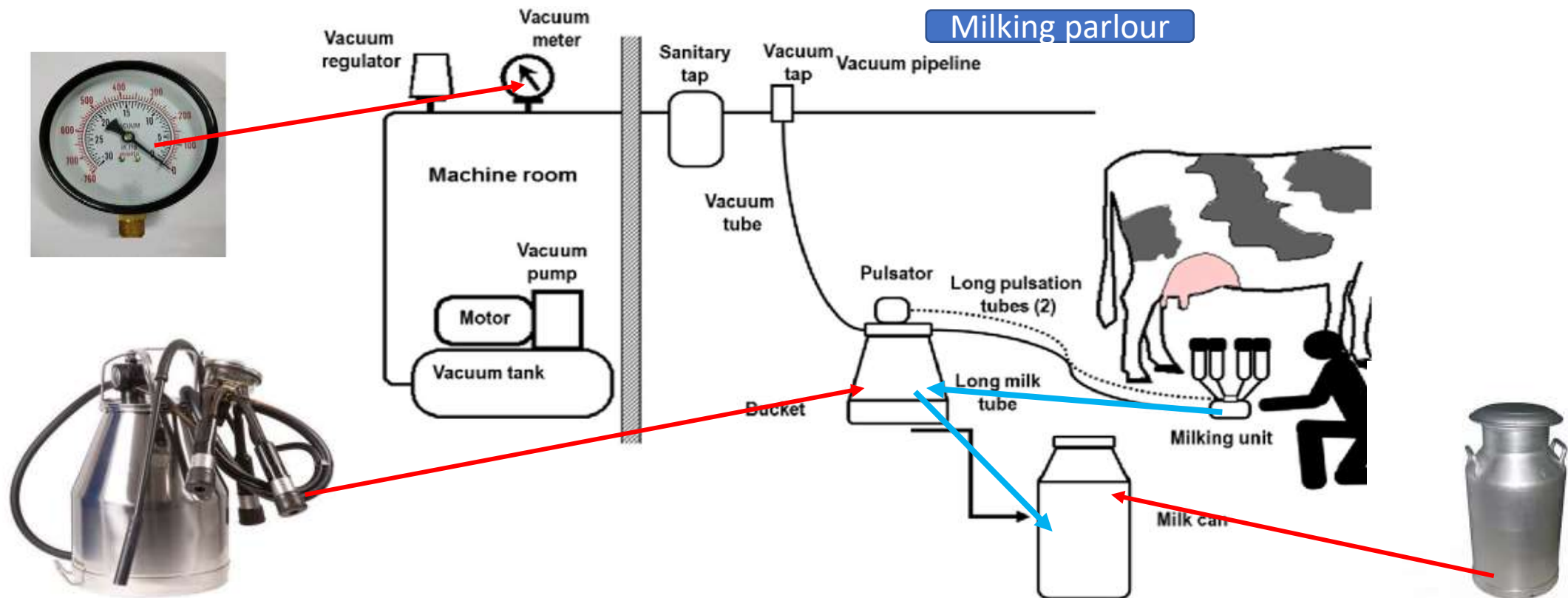

12.2 Tools and equipment in more advanced farms Cont'd: Milk machines with pipelines

- Milk is transported from the cow through milk tube to be first measured, then further transported to cooling tanks through milk pipelines (follow the blue arrows).

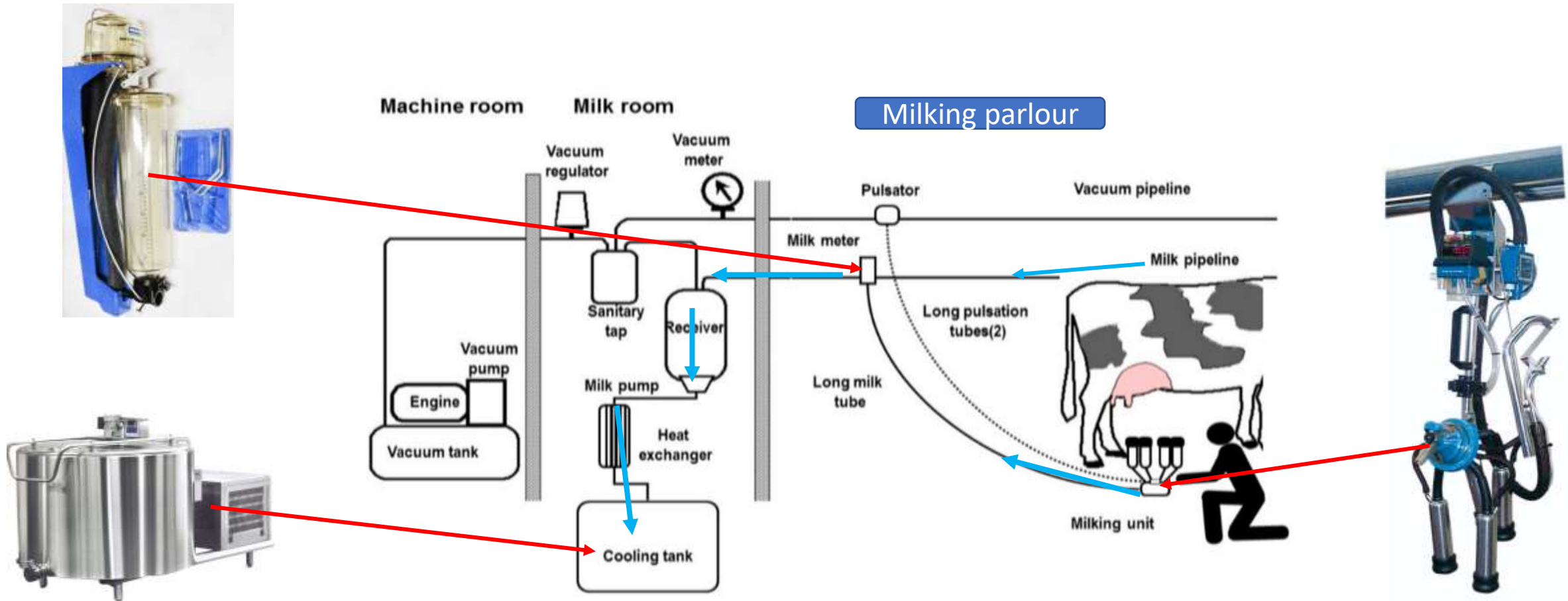

12.3 Tools and equipment in more advanced farms Cont'd: Milk transporting equipment and tools.

- Milk can be transported in milk cans or bulk tankers with coolers, which should be suitable for effective cleaning and sanitization.
- Generally, milk from small-scale milk producers is transported in milk cans by the producers themselves or by milk collectors (informal traders and intermediaries).



12.4 Tools and equipment in more advanced farms Cont'd: Fodder establishment, harvesting, and conservation

- The fodder establishment, harvest, and conservation have the main machinery called the tractor.
- The tractors have several implements that are attached to perform different roles such as choppers, harvesters, ploughs, planters, mowers, balers, etc.
- The types of these implements and functions have been covered under the modules; **1.10. Operating farm equipment and self-propelled tractors**



13. Implements for land preparation

- Implements for land preparation include ploughs and harrows.

- i. Disc plough
- ii. Mouldboard plough
- iii. Chisel plough
- iv. Disc harrow
- v. Spring tooth harrow



14. Implements for planting forage

- Planter; calibrated to place seed and fertilizer. The planter has a furrow opener and also can cover the seeds and fertilizer after placing them on the furrow.

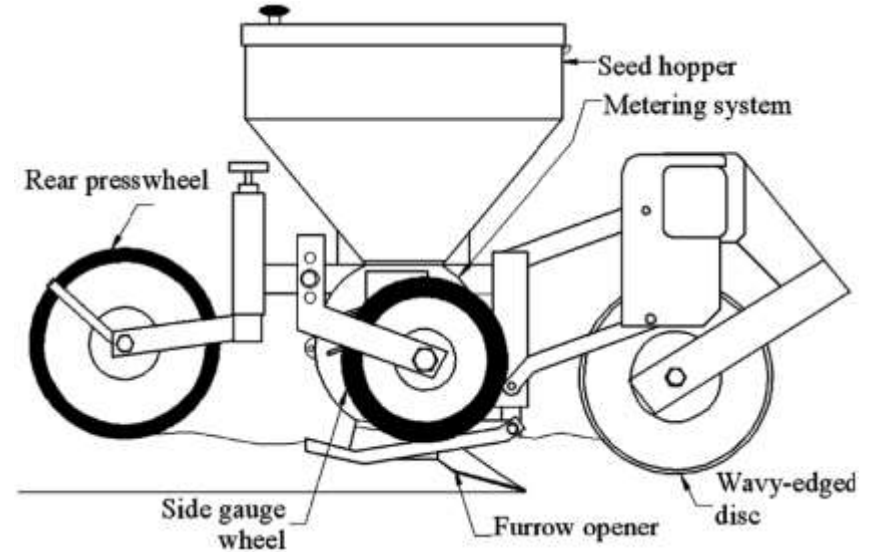

15. Implement for forage management

- i. Boom sprayer; spray for example pesticides on the forage.
- ii. Bush clearer/chain mower; level pasture after grassing cows.
- iii. Manure spreader; spread manure on the pastures and land prepared for forage establishment.
- iv. Fertilizer spreader; can be used to top dressing fertilizer.



16. Implements for harvesting and silage conservation

- i. Silage harvester; cut and chops and move it to collecting trailer or baler.
- ii. A trailer; mounted to a tractor or lorry for transportation of forage to be ensiled and or baled.
- iii. Silage baler; used to bales silage.



17. Implements for harvesting and hay conservation

- i. Hay mower; Cuts forage and place them on the ground before baling.
- ii. Hay rake; Gathers cut forage before baling
- iii. Hay baler- Collects cut forage and bales to hay bales.

