

COW HOUSE GROUND FLOOR PLAN DESIGN (SNV BOOK) (Level 3)

Topic	Training & information Content
8.1	Farm structures & housing cows/calves/young stock
8.2	Construct small zero grazing unit (SNV handbook)
8.3	Prevention of heat stress in cow barns
8.4	Cow house ground floor plan design (SNV book)
8.5	Best management practice feed fences.....
8.6	Housing & cow comfort (animal welfare)
8.7	Housing & reduction greenhouse emissions
8.8	Use of sensors (activity meter) in dairy herds



1. You will learn about (learning objectives):

- ❑ Factors to consider when making a floorplan.
- ❑ Considerations in floor & cubicle design.
- ❑ Understand the importance of cow movement.
- ❑ Floor construction basics & critical checkpoints in cow cubicles.



2. Introduction

- Floorplan is a diagram or design of a cow house layout, drawn to scale to allow one map out exactly how one would like details of the cow house to appear.
- Floor plans show relationship between the different compartments of the cow house (e.g. standing or feeding alley, walking alley, resting area, milking parlour etc.)
- Floors should be placed on undisturbed, firm soil (stable ground).

Top view of head to head barn

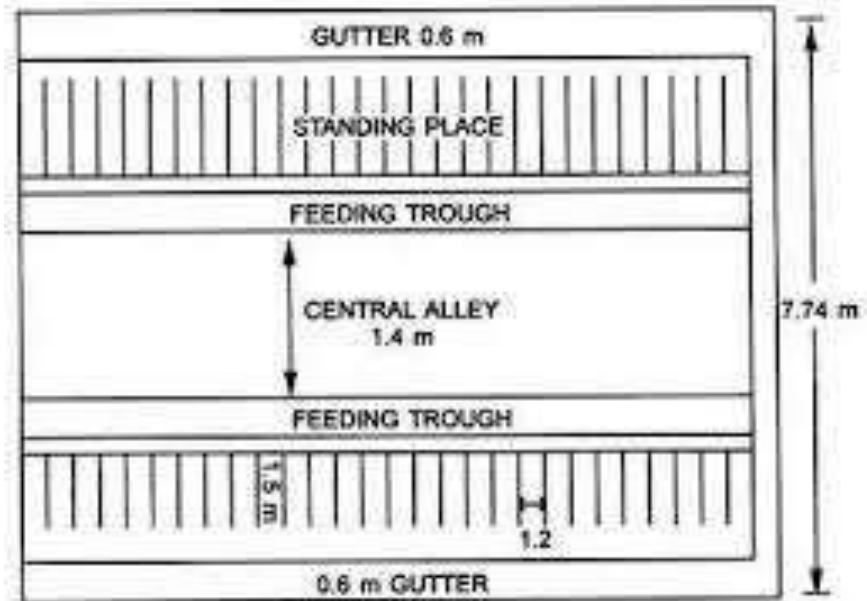

3. What to consider in floorplan measurements

- Animal movement.
- Animal size.
- Cubicle size.
- Cow comfort.

Animal size and movement

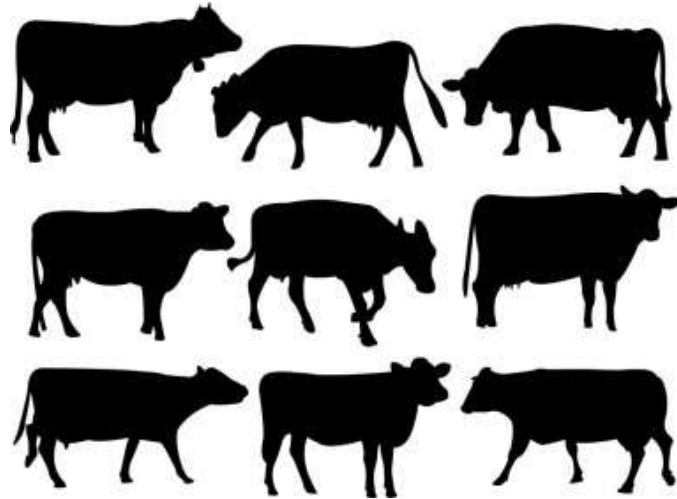

Type of cubicle divider

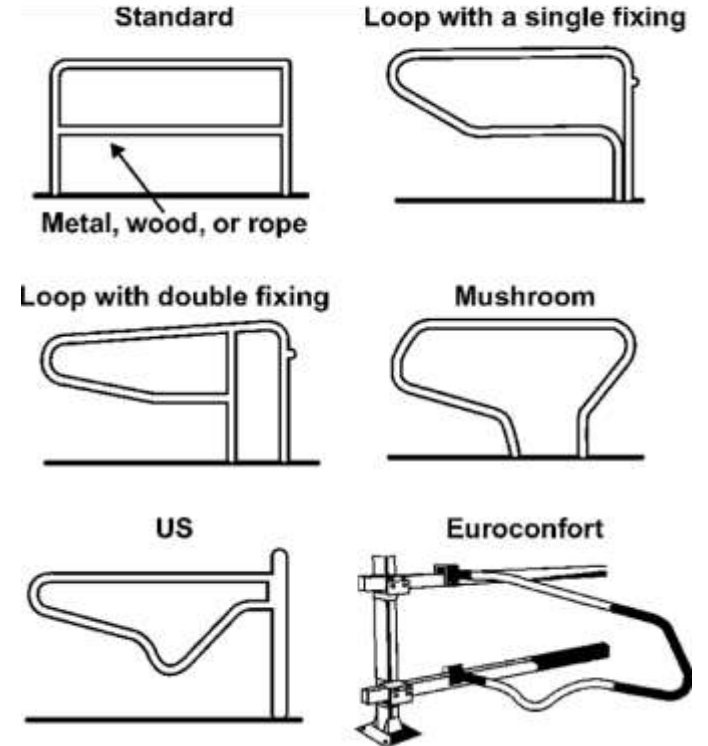

3.1. Animal movement

- Step one in constructing a cubicle is first to understand how the cow lays down and stands up.
- In front, a cow needs sufficient space, for her forward movement while standing up.
- The front half of a mature cow represents approximately 55% of her body weight.
- Proper positioning of the legs, with sufficient grip is important in order to use the least amount of energy, the cow needs, to stretch her front leg forwards.



3.1.1 Animal movement, Cont'd: **Cow traffic**

- Cows should walk easily in pastures, on farm roads and in a cow barn/zero grazing unit.
- It is recommended that two cows should be able to move easily, pass each other in either direction in walking alleys.
- A cow should be able to walk in and out of a cubicle at any given time .
- Cow barn interior should not predispose a cow to injury or cause a hinderance to other cow's.
- Unnecessary movement (traffic) of cows should be avoided in cow barns.



3.2 Animal size

- Step two is to measure the average dimensions of the cow's in the herd before construction.
- Knowing the size of cows is crucial since different cow breeds vary in size and weight.
- The design should be based on the standard size of the breed one intends to keep.
- But even within the same breed, size of cow's in a herd differs depending on various factors (for example: calf rearing).
- Knowing the size and weight of the cows in your herd will guide the farmer how to make adjustments for his particular herd.

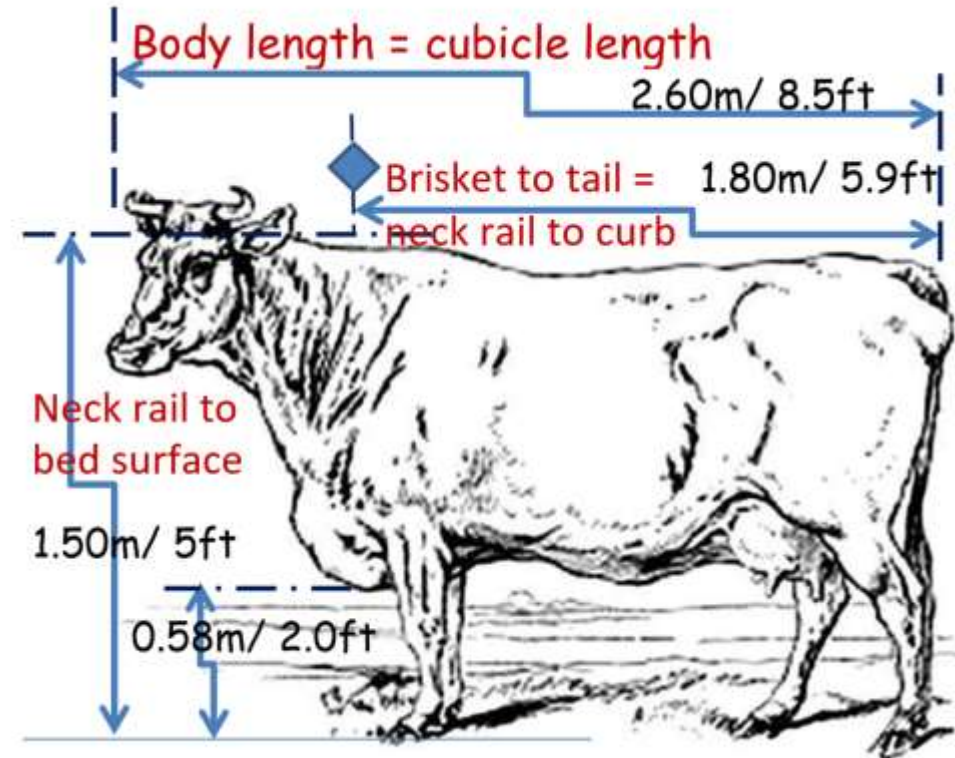

3.3 Cubicle size

- The cubicle has many parts that a farmer should put in mind to ensure that the animal fits well within a cubicle at ease.
- This parts include:
 - 1) The cubicle dividers
 - 2) The length and width of the cubicles.
 - 3) Bedding material
 - 4) Neck rail
 - 5) Brisket locator
- No part/object in a cubicle should take up space intended for the cow to rest in.

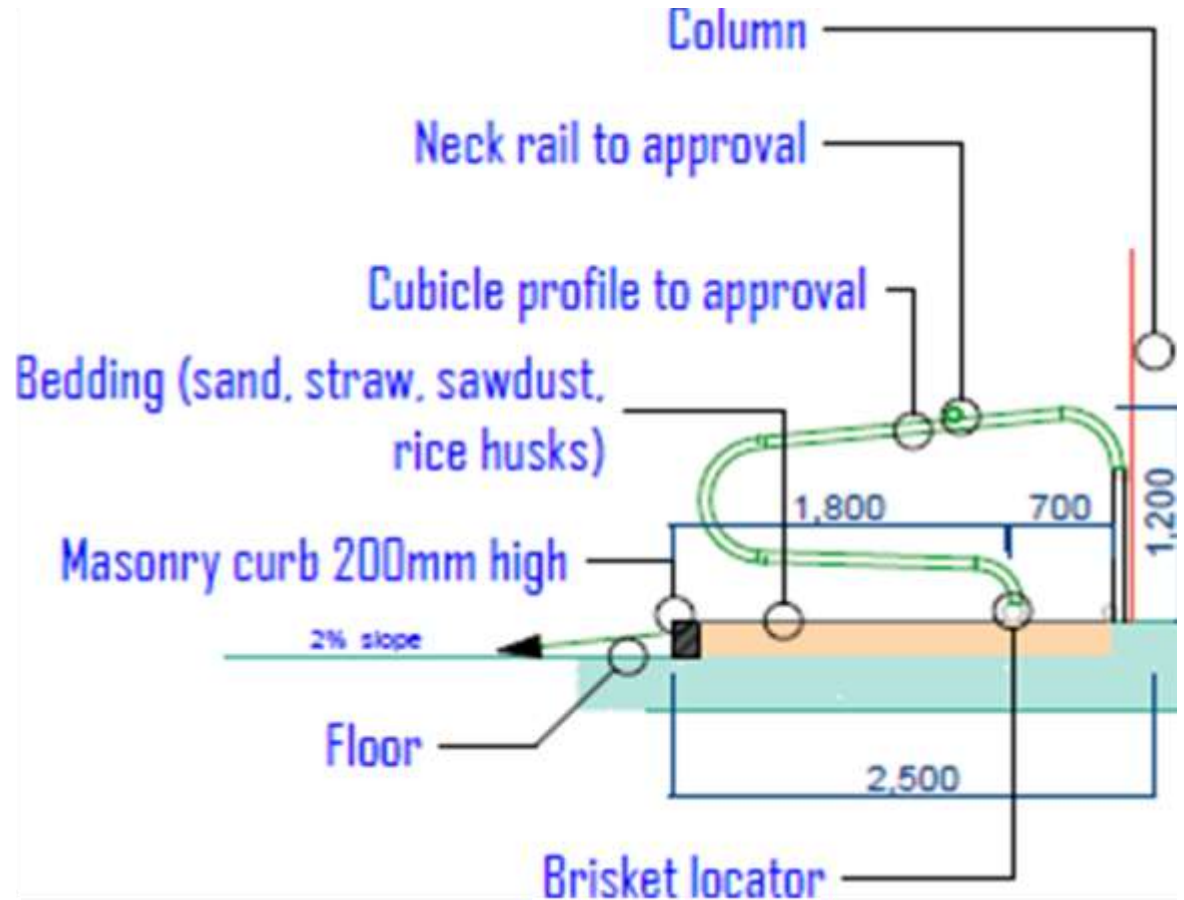

3.3.1 Cubicle divider

- Cubicles divider directs the cow to go into a particular cubicle and allows her to lie straight.
- This helps in ensuring that manure and urine are deposited outside to cubicle keeping the cubicle clean and dry.
- Cubicles dividers have gone through series of changes from standard divider to mushroom and later to the US model, all these advancements to ensure cow comfort.
- Lately there are cubicle divider that are flexible, moves when cows lie on them away from the rigid cubicle dividers.

Type of cubicle divider

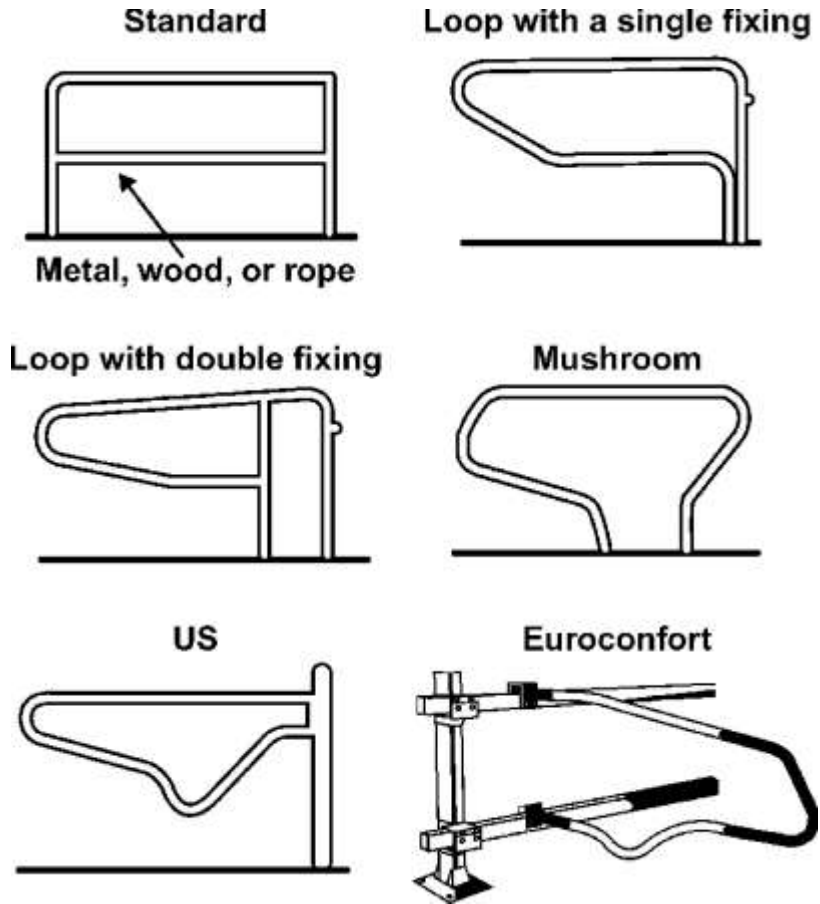

3.3.2 Length and width of the cubicle

- Cubicles length and width varies depending on type of breed, however there is a standard measure that farmers can go with.
- Cubicle for an adult cows should be approximately 2 - 3m long and 1 – 1.5m wide, open head space, neck rail & brisket locator in adjustable positions.
- When the neck rail is placed too far backwards it causes the laying area to be short affecting cows laying comfort.

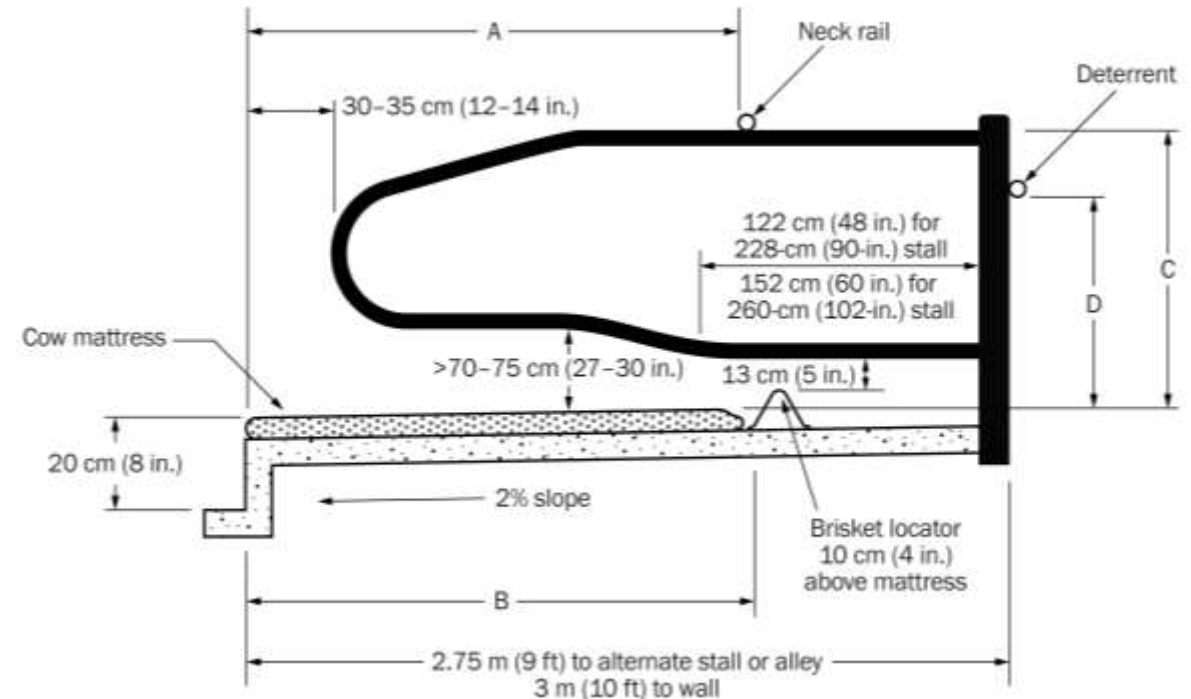

3.3.3 Bedding

- Cubicle beddings should be dry soft, comfortable and kept clean regularly.
- Bedding material should also be changed and where necessary bedding should be kept level by topping up the bedding material in question.
- Bedding material used are either: soil (sand), dry materials (straws, saw dust) and mattresses or mat.
- See module on: Housing & Cow comfort (animal welfare).



3.3.4 Neck rail

- The neck rail is an important part of the cubicle, it greatly affects the getting up and laying down of the cow.
- The neck rail is placed approximately 110-125cm above the bedding.
- It is observed that the height of the neck rail causes external injuries if not well placed.
- Neck rail should be placed such that cows do not step too forward and should ensure enough space is left for laying down.

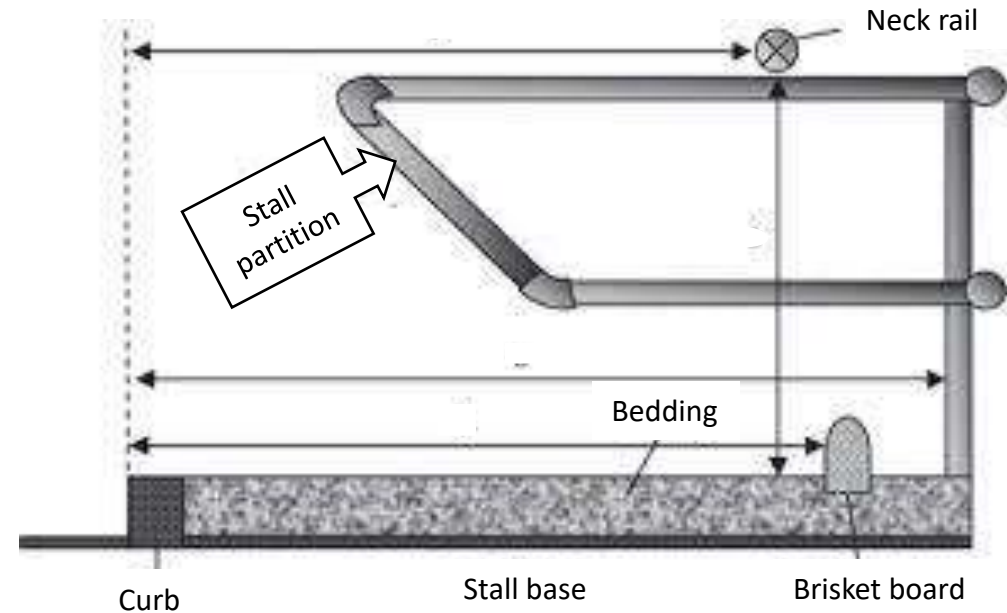

3.3.5 Brisket locator

- Brisket locator may be placed approximately 160-180 cm from the curb of the cubicle.
- Animal welfare is influenced by position of the neck rail, brisket locator and bedding material.
- Keep in mind the dimensions depend on the size of the cubicle

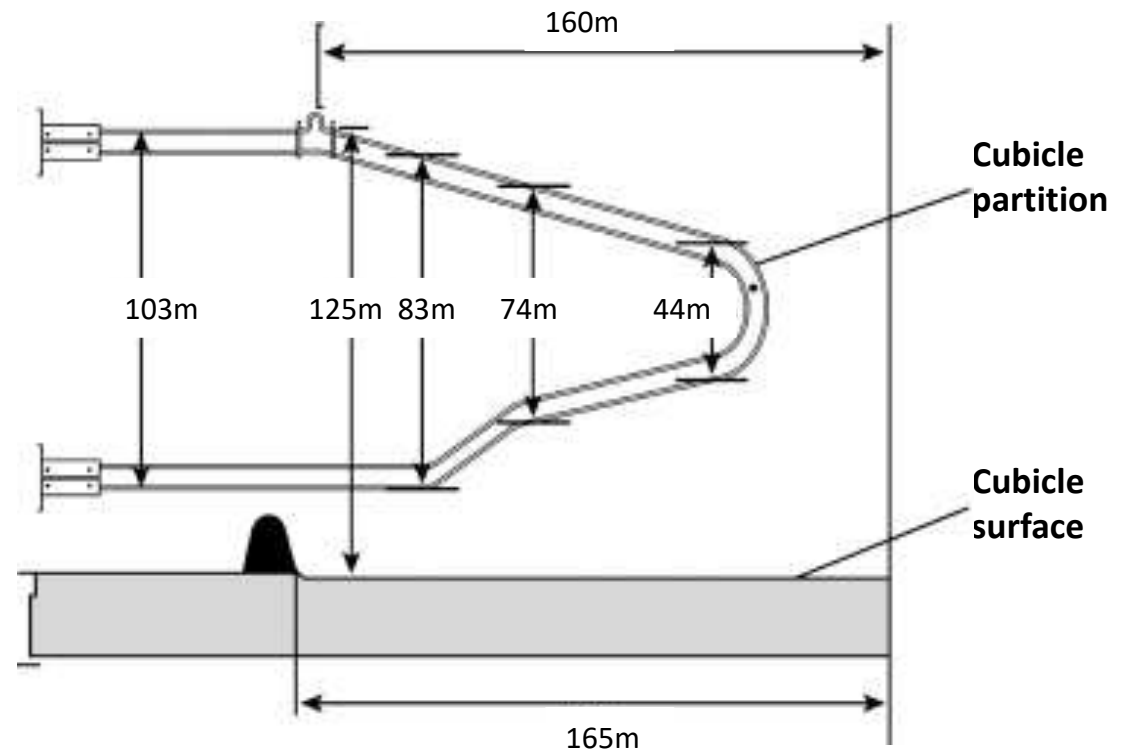

3.4. Cow comfort

- Space between the dividers and the length of the cubicles should be enough for a comfortable head swing (forward movement of the cow while standing up) of the cow.
- The cubicle should be comfortable with soft bedding material.
- The floor should be able to provide grip and footing for the cow to give the cow confidence and comfort while standing up.
- Without considering dimensions and appropriate structural parts of the cow barn design, cows may experience hinderance in their movements which causes injuries.



4. Resting area

- The cow needs a replication of the natural setting of the resting area, for example: the pasture, there is enough space for the cow to get up and the pasture generally provides a soft bedding.
- Cows always select the best place to lay down in a barn or outside in the pasture by observing the cows we can understand their natural behavior.
- In an indoor setting, the resting areas should therefore be rammed earth with suitable, soft bedding material. Cubicle floors should be comfortable enough for high lactating cows to lay down at least 12 hours per day.
- The resting area should be raised from the walking area at least 25cm above.



5. Considerations in floor & cubicle design

1. Flooring- Wet floors makes cows susceptible to skidding and sliding which can cause injuries when fall is fatal.
 2. Headspace- The cubicle needs a minimum width of 115cm for a 135cm high cow for easy head swing.
 3. Design- The dimensions of the cubicles can be easily adjusted by movable neck rail and brisket locator.
 4. Matching cow sizes with stall dimensions- Within a herd cows can get bigger, smaller, shorter or longer over time these variations affect use of cubicles.
- For this reason stalls should be assessed every 3 months to determine if calves, heifers and cows are still fit comfortable in the cubicles.



5.1 Considerations in floor & cubicle design Cont'd...

- Bedding material can either be: soil/sand, chopped straw, sawdust, dried manure, and other dried materials.
- Sand is the best bedding material followed by deep bedding materials such as: sawdust, chopped straw.
- Due to the possibility of homemade mattresses and rubber mats becoming hard, it is important to provide some soft dry material like sawdust which can absorb some urine/manure which needs to be removed 2-3 times per day to keep the laying area dry.
- Research shows 5cm of sawdust should be used on thick (4-6cm) rubber mattresses and at least 10 cm on rubber mat(2-3cm) and minimum of 20cm on a concrete floors.



6. How a cow is standing up

- 1) Cow at rest
- 2) First the cow lifts her head and brings her front legs under her chest.
- 3) She stretches her head forward as a counterbalance for her back end. The front legs function as the balancing point. This cow is now more than 3m long.

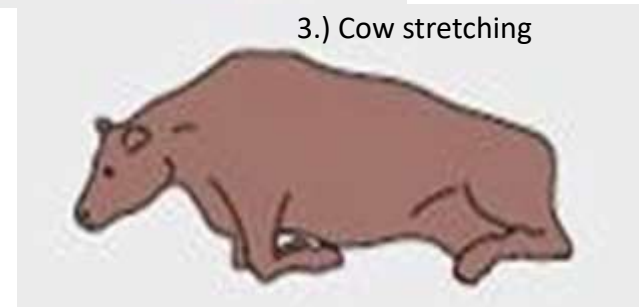
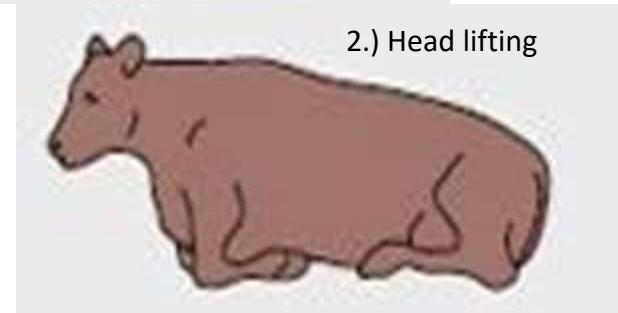
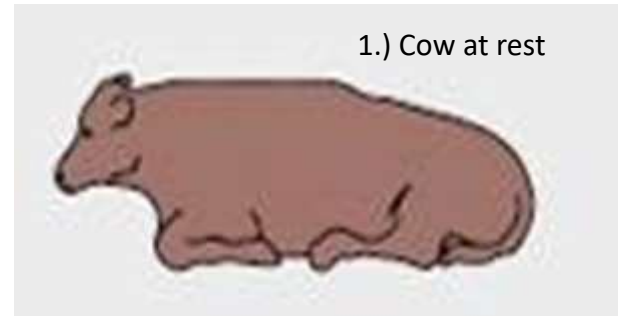

6.1 How a cow is standing up, Cont'd...

4) The hind legs are positioned under the body. Her head is almost on the ground.

5) The head is being retracted again and the cow puts one front leg forward in order to maintain her balance.

6) Finally, the fourth leg is positioned and the animals can begin walking, but not until she takes a moment to stretch.

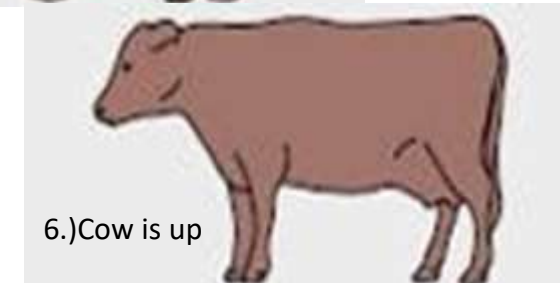
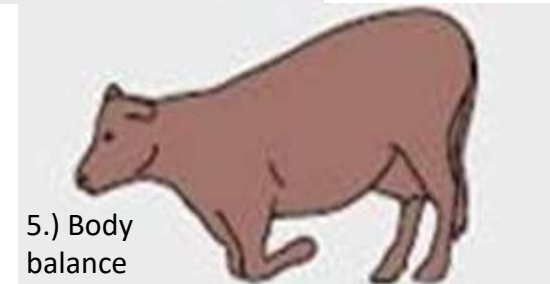

7. Floor construction basics

- Set forms so that the concrete slab surface slopes a minimum of 2% to provide adequate drainage.
- Use a poker vibrator to drive-off trapped air and decrease bonding ability in addition to scratch template.
- Usually, a piece of 2 by 4 or 2 by 6 lumber equal to the specified slab thickness with stakes attached to the top surface at each end or string line across the top of the forms to ensure proper slab thickness.



Poker vibrator

https://snv.org/assets/explore/download/kmdp_-_handbook_modular_cow_barn_design_for_smallholder_dairy_entrepreneurs_0.pdf

7.1 Floor construction basics Cont'd...

- Strike off the surface while keeping a small amount of concrete in front of the straight hedge to fill low spots, this prevents bird births in the finished surface.
- Use a groover to make contraction joints in the fresh concrete, make sure the groove depth is $\frac{1}{4}$ of the slab thickness.
- Or use expansion joints at predetermined spacing, or saw joints using early-cut saw or convectional saw. Early jointing helps prevent cracking due to temperature change.
- Starting curing the concrete immediately after completion of finishing operations.



Type of expansion joints

https://snv.org/assets/explore/download/kmdp_-_handbook_modular_cow_barn_design_for_smallholder_dairy_entrepreneurs_0.pdf

8. Critical checkpoints for cubicles

- Cubicles can get in the way of the cow standing up and laying down. If you understand how cows normally lie down, you stall better so that your cows get maximum rest and do not injure themselves.
- To lay down and to stand up, the cow needs enough space to swing her head forward.
- This space can also ensure good ventilation and fresh air circulation in the barn.
- Soft bedding provides a soft landing, soft laying, and a good grip so that the cow's claws do not slip away underneath from her.

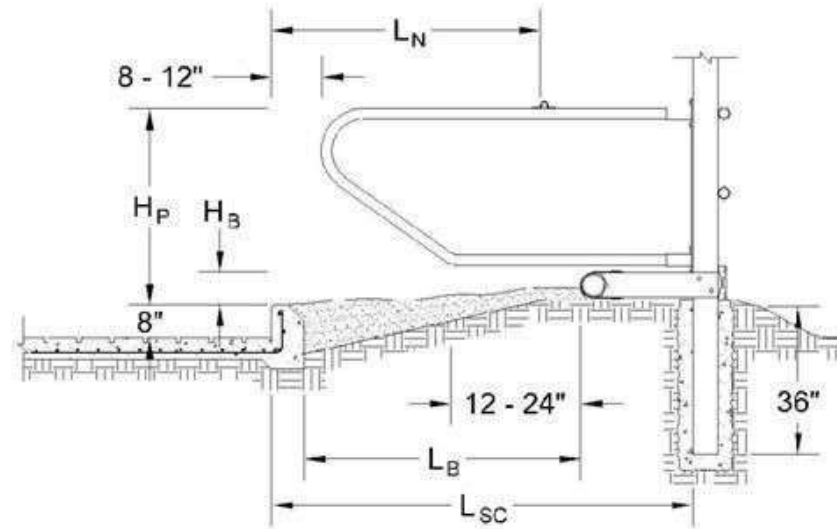
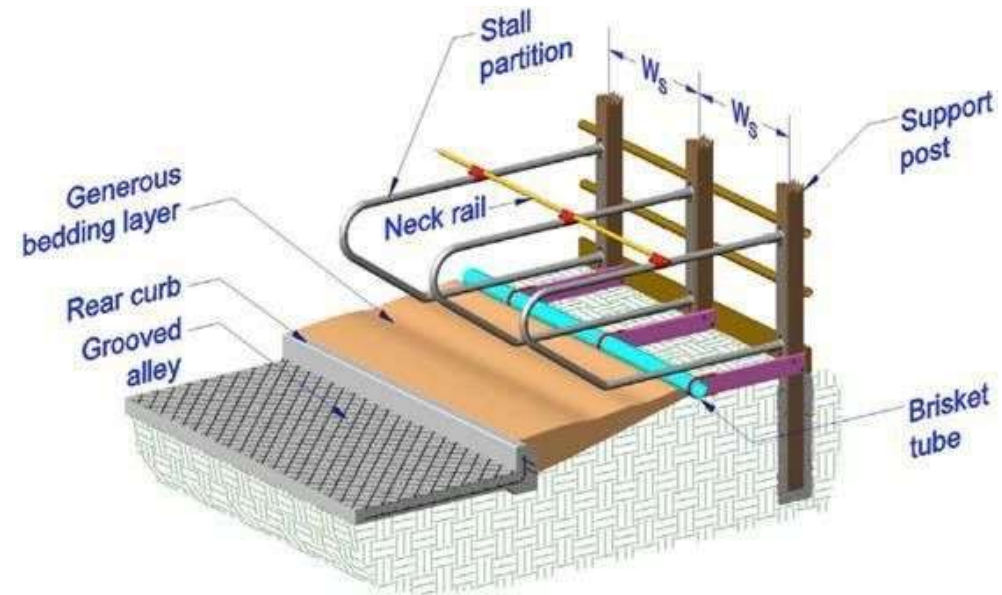

**Closed Front Freestall
with Generous Bedding**

8.1 Critical checkpoints in a cubicle, Cont'd...

- Loose, soft bedding material is much better than rubber or homemade mattresses. As long as the thickness of the bedding material is minimum 20 cm or more.
- Loose bedding material needs to be leveled in the cubicles 2-3 times per day.
- Clean out manure and wet bedding material from the cubicles 3-4 times per day.
- Ensure that the top of the bedding material is always dry.



9. Floorspace partitions in a cow barn

- Calves/youngstock.
- Lactating cows.
- Milking parlour.
- Water trough.
- Feeding alley.
- Walking alley

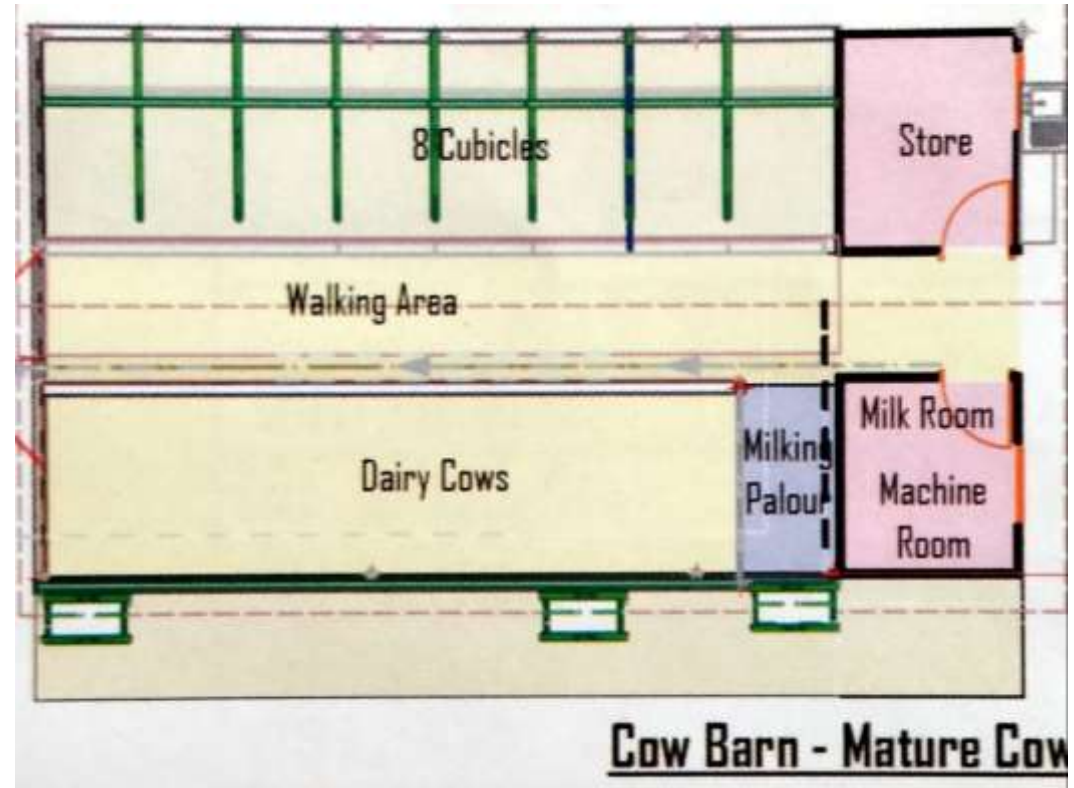

9.1. Calves/Youngstock ground floor plan

- It is recommended that the calf pens are raised.
- The ground floor area below the calf pen should be slanting/elevated & slatted for drainage purpose and easy cleaning.
- For calf pens made of wood, spaced between the wood can be approximately 2.5cm to allow urine and faeces to fall on the ground.
- The ground should always be dry & clean to avoid diseases.
- Where the ground floor is soil, it should allow seepage/drainage of water/urine.



9.1.1 Calves/Youngstock ground floor plan Cont'd:

Floor space measurement

Floor space (meters square)	Age of youngstock
1.86 – 2.32	3 months
2.32 – 2.79	3 – 6 months
2.79 – 3.72	6 – 12 months
3.72 – 4.18	above 1 year

Vikaspedia : Housing for dairy cattle



9.1.2 Calves/Youngstock ground floor plan

Cont'd: **After weaning**

- After weaning the youngstock are placed in groups depending on age and weight.
- Here youngstock are housed on the ground (not raised houses) but the floor should be roughened and slant for urine and water drainage.
- The floor can be made of concrete and bedding should be enough apart of the area space should be accommodated for youngstock to play and is not filled with bedding material.



9.2 Lactating cow ground floor plan

- Cow barn floor area for an adult cow should be approximately 6 – 6.5 meter square.
- Floor should slant at a gradient of about 2 – 3 cm from the resting area to the manure storage channel.
- Floor should be roughened and maintained dry always.
- Group cows according to: stage of lactation and exception can be made for first calvers who are generally a bit smaller.

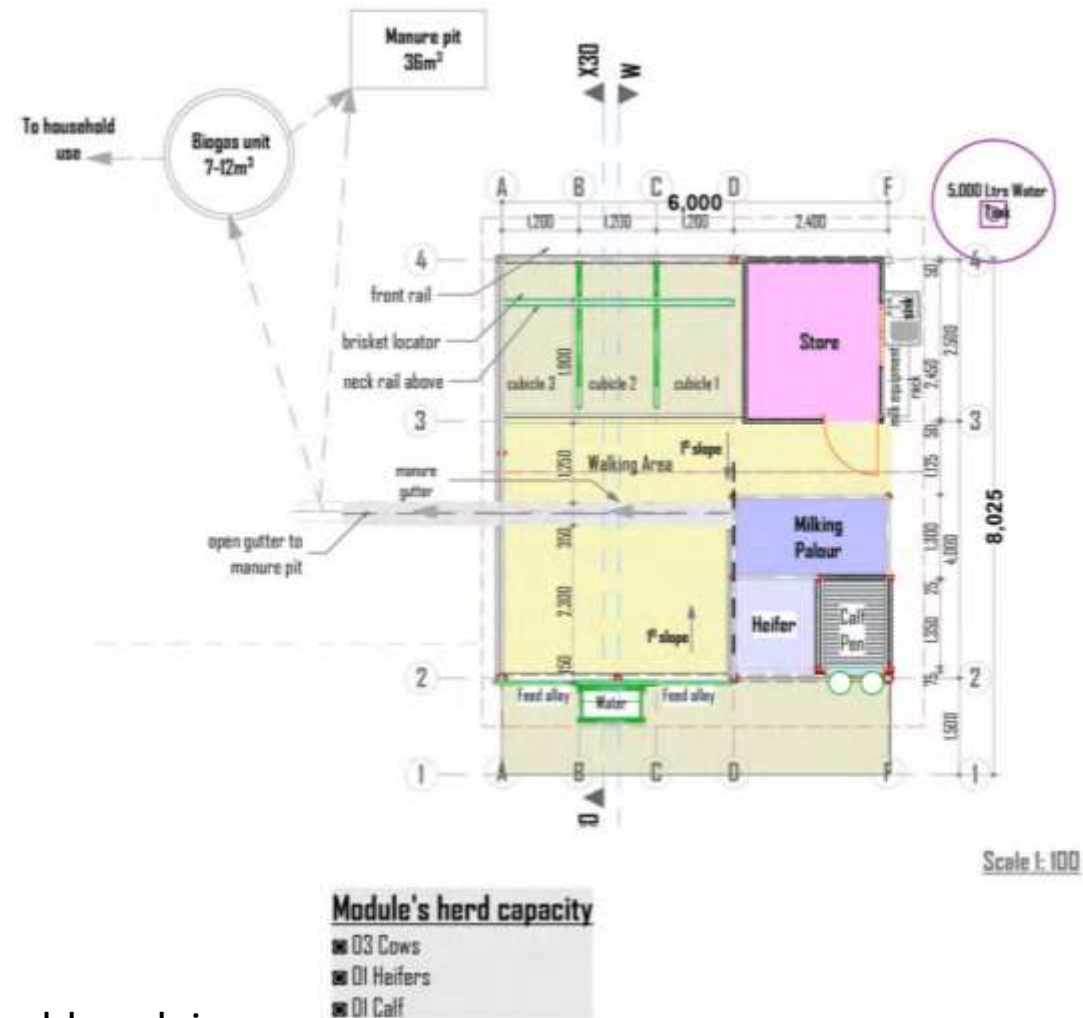

https://snv.org/assets/explore/download/kmdp_-_handbook_modular_cow_barn_design_for_smallholder_dairy_entrepreneurs_0.pdf

9.3 Milking parlour

- The milk parlour should be constructed with considerations of both the cow and worker.
- Floor space should accommodate the cow and worker to be able to either do hand milking or attach & detach a milking machine at ease.
- Space set aside could be more especially for the worker depending on the type of milking parlour.

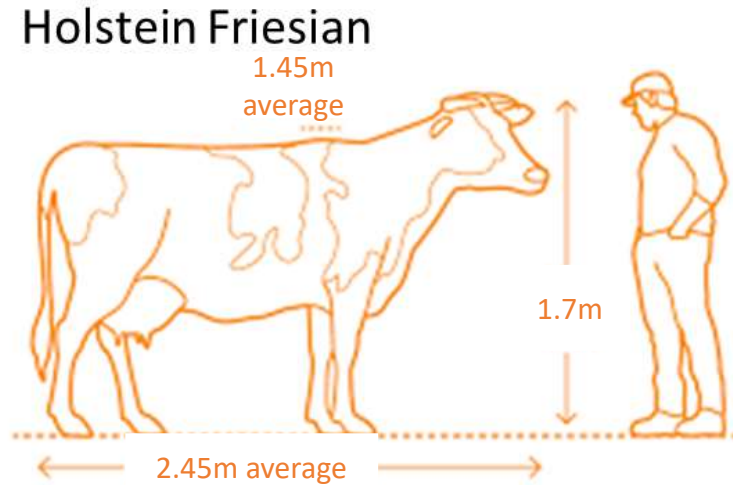

9.3. Milking parlour Cont'd:

Herringbone & parallel milk parlours

- Parallel milk parlour uses less space than herringbone milk parlour.
- For herringbone parlour more space is allocated where the worker stand, milking equipment is placed and accommodates many cows.
- The milk machine plus workers space is between the 2 rows of cows , the worker milks while standing behind the cows, this area is often smoothly cemented or tiled.

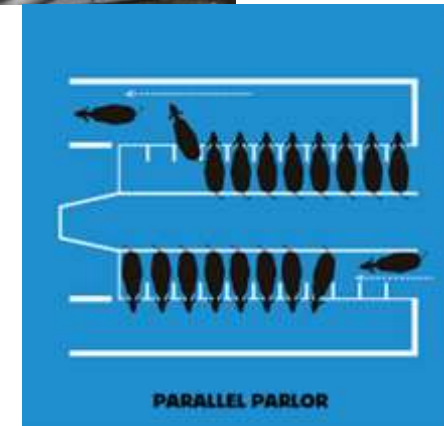
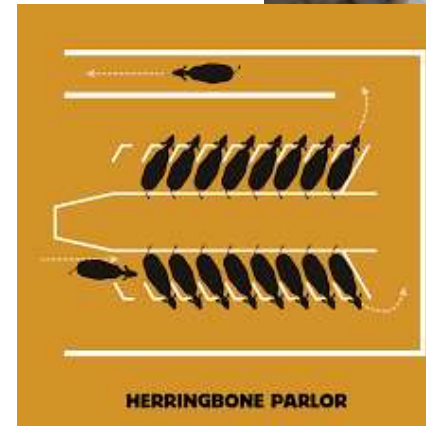

9.4 Water trough

- Water trough should be centrally located where cows are able to spot (corner of the barn).
- For semi-permanent water troughs (metal) should be firm by adding reinforcement to withstand push and pull that cows can get into when in the drinking spot.

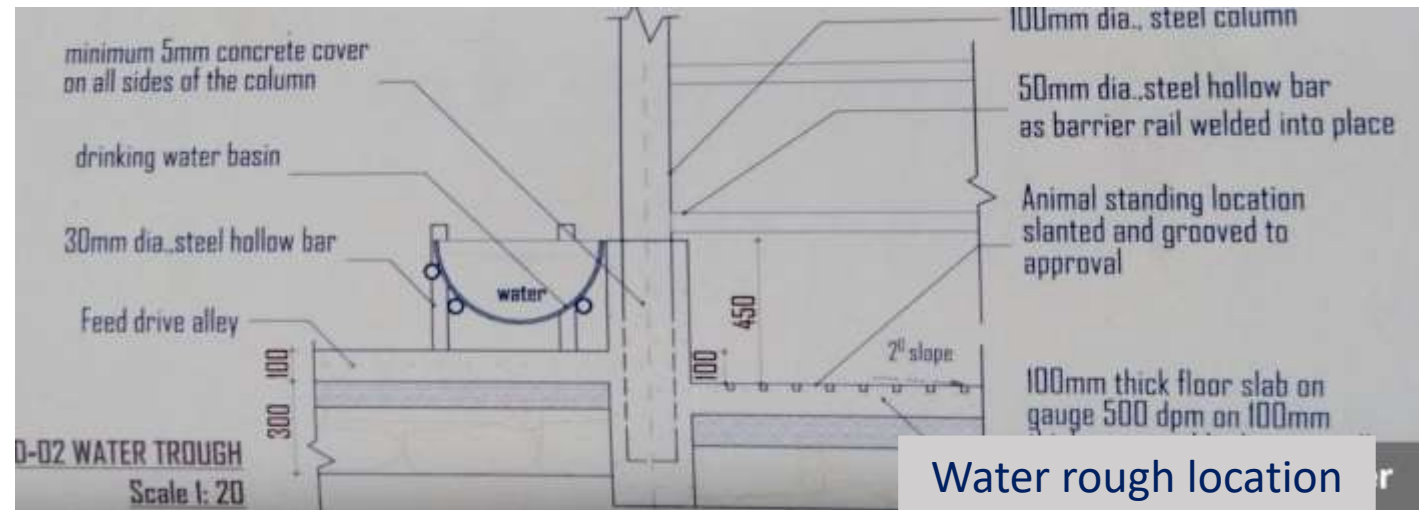

9.5 Feeding alley

- Feeding alley is a pathway after the feed fence either in one row or between two rows with cows facing one another in a cows barn.
- The feeding alley dimensions vary depending on the farmers choice of feed delivery.
- It should be on uniform ground and levelled to avoid stagnant water.

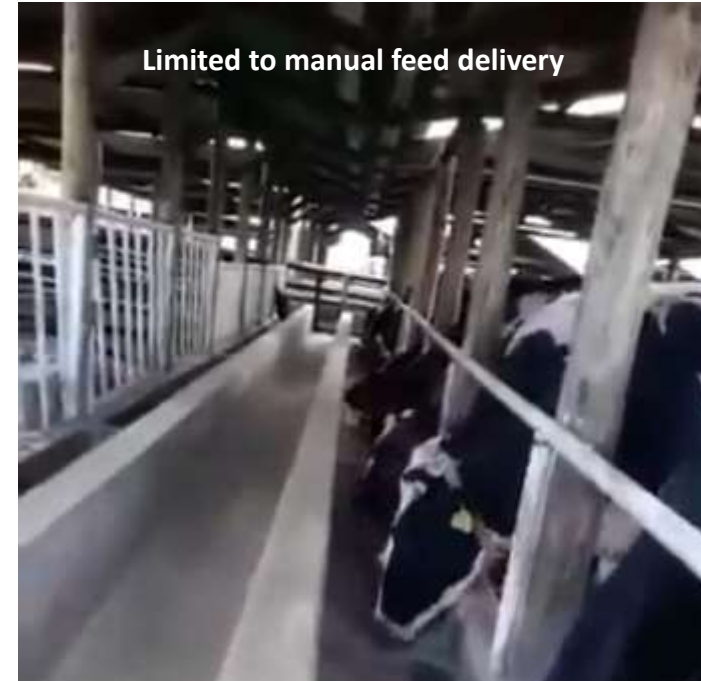

9.5 Feeding alley, Cont'd...

- For a single row feeding alley a farmer can either decide to place concrete partly or fully in a feeding alley (table).
- Farmer may place concrete for 1.25-1.5m wide to accommodate unlimited feed, feed leftovers should be less than 5%.
- For a two row, with cows facing each other feeding alley it is recommended to have space of 5m.



9.6 Construction of the walking alleys

- All walk alley should be constructed of good quality concrete (15 cm thickness), with an iron concrete grid (diameter: 6 or 8 mm, grid distance: 15 cm).
- All longitudinal walkways should be on a slope of 1.5 to 2.5% (1.5 to 2.5 cm per 100 cm) in two directions: towards the center and towards the manure dump.
- For easy cleaning, the holding pen can be built on a slope of 3-5 % away from the milking parlor towards the manure dump.



9.6 Construction of the walking alley, Cont'd...

- To provide sufficient grip for the cows, the concrete must not be polished.
- In most cases concrete floors are roughened (grooving) or a rubber layer is applied to create more grip.
- Walking on rubber is more comfortable because landing of the claw on soft rubber is more comfortable than hard concrete.
- This type of surfaces are also found in the milking area due to heavy cow traffic.



10. Example of bad cubicles

- Poorly built floors (uneven/cracked floors).
- Poor bedding (hard floors).
- Poorly constructed cubicles (position of cow in the cubicle).
- Cleanliness (wet floors & poor dung/manure management).



10.1 Example of bad cubicles Cont'd: **Poorly constructed cubicles**

- **Signs of a short resting area to cow size:**
 - Cows laying diagonally since there is not enough space at the front.
 - Or the neck rail is too far backwards.
- **Signs of a large resting area to cow size:**
 - Cows depositing urine and manure in the cubicle.



11. Floor and hoof health

- It is important to consider when making the floor plan that the hooves are in constant contact with the floor when the cow is standing or walking.
- Hoof health is important because hoof injuries can cause lameness and this is generally a greater problem for confined cows compared to cows that are grazing.
- Hooves bear the weight of the cow and any problems, injuries predispose cows to lameness.
- Cows prefer soft and dry surfaces to walk and rest comparable with a green lush pastures.

