

BEST MANAGEMENT PRACTICES

FEED FENCE (Level 3)

Topic	Training & information Content
8.1	Farm structures & housing cows/calves/young stock
8.2	Construct small zero grazing unit (SNV handbook)
8.3	Prevention of heat stress in cow barns
8.4	Cow house ground floor plan design (SNV book)
8.5	Best management practice feed fences
8.6	Housing & cow comfort (animal welfare)
8.7	Housing & reduction greenhouse emissions
8.8	Use of sensors (activity meter) in dairy herds



1. You will learn about (learning objectives):

- What is a feed fence and types of feed fences.
- What to consider while designing feed fences and parts of feed fences.
- The best management of feed fences.



2. Background

- A cow prefers to graze in the field naturally as shown in the picture.
- For zero-grazing systems, a cow is provided with feeds and served in a feed table or troughs that are separated from the walking area with feed fences.
- Quite a number of feed fences/barriers are designed poorly and therefore are not comfortable for the animals to feed.
- On poorly designed feed fences we can often make the following observation;
 - The animals have injuries, on the neck, brisket, and knees, (e.g. bald patches of skin).
 - As a consequence the animals may reduce feed intake.



3. Introduction

- The feed fence should be comfortable for the cow. It should not inconvenience or cause any obstruction for the cow because this will discourage them from eating.
- It is important when planning the cow barn to ensure that dimensions and design are compatible with the type (size) of the cow.
- As earlier mentioned wrong dimensions may cause injuries such as horn breakage, bruises, bald patches, and even restrict feed intake.
- By a proper design or readjusting the feed fences according to recommended dimensions the farmer can make feeding comfortable cow.
- Feed fence management is also important to ensure the fence is well maintained and remains in good condition.

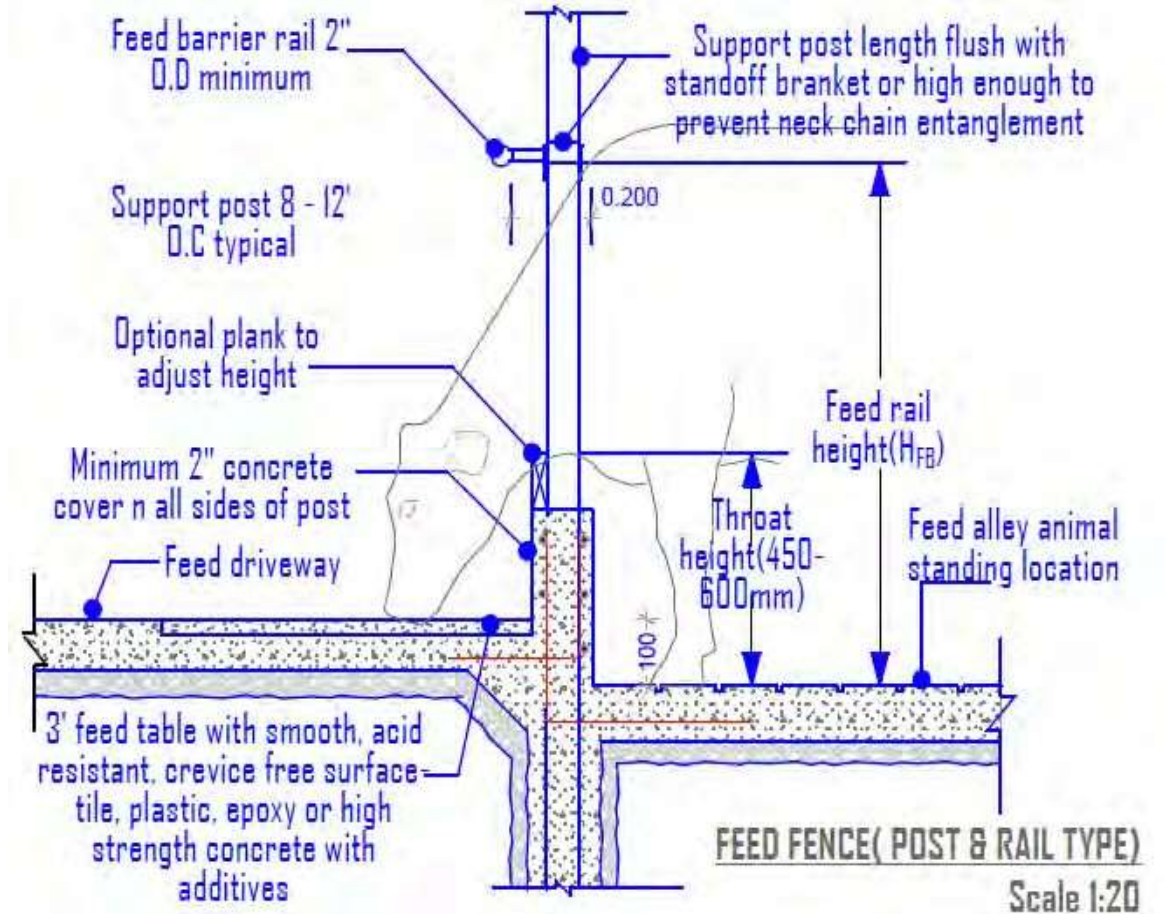

4. The purpose of feed fence

- A feed fence is a barrier separating the cows from the feed table or feed troughs.
- The main purpose is to stop cows from stepping into the feeds and cause contamination, reduce palatability, and eventually spoilage.
- The cow can contaminate the feeds by, stepping, defecating, or urinating on the feeds.
- Feed fences should be adapted to the size (breed) of the cows.



5. Parts of a feeding area in a zero-grazing system

- The feeding area of a cow barn constitutes three main parts which are ;
 - 1) The feed fence,
 - 2) The feed table; feed alley or feed trough and possibly water troughs or bowls,
 - 3) The walking/standing alley where the cow feeds.
- These three parts affect the feed intake of a cow if not well constructed and designed.

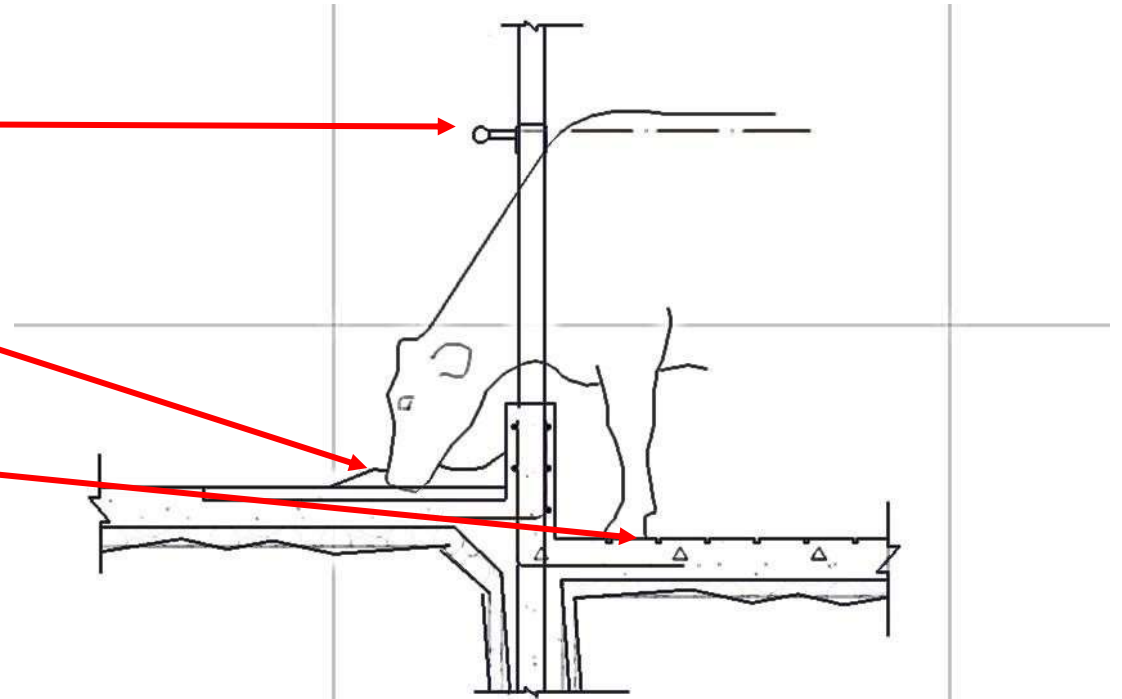

6. Types of feed fence design

- There are different types of feed fences in zero-grazing systems;
 - Swedish feed fence,
 - Diagonal feed fence,
 - Head (self) locking feed fence,
 - Tie-stall feed fence design



7. Swedish feed fence design

- A Swedish feed fence is designed not to touch the neck of the cow but to stop the animal at the shoulder. This type of feed fence doesn't have a neck rail. The main advantage of this type of feed fence is that it matches with cows of almost all sizes because it has no neck rails.
- However, if the same dimensions are used for mature cows and young calves they might step through it. Therefore, different dimensions can be used for young stock with a high variation in body size. See examples of a Swedish feed fence in the figures below.

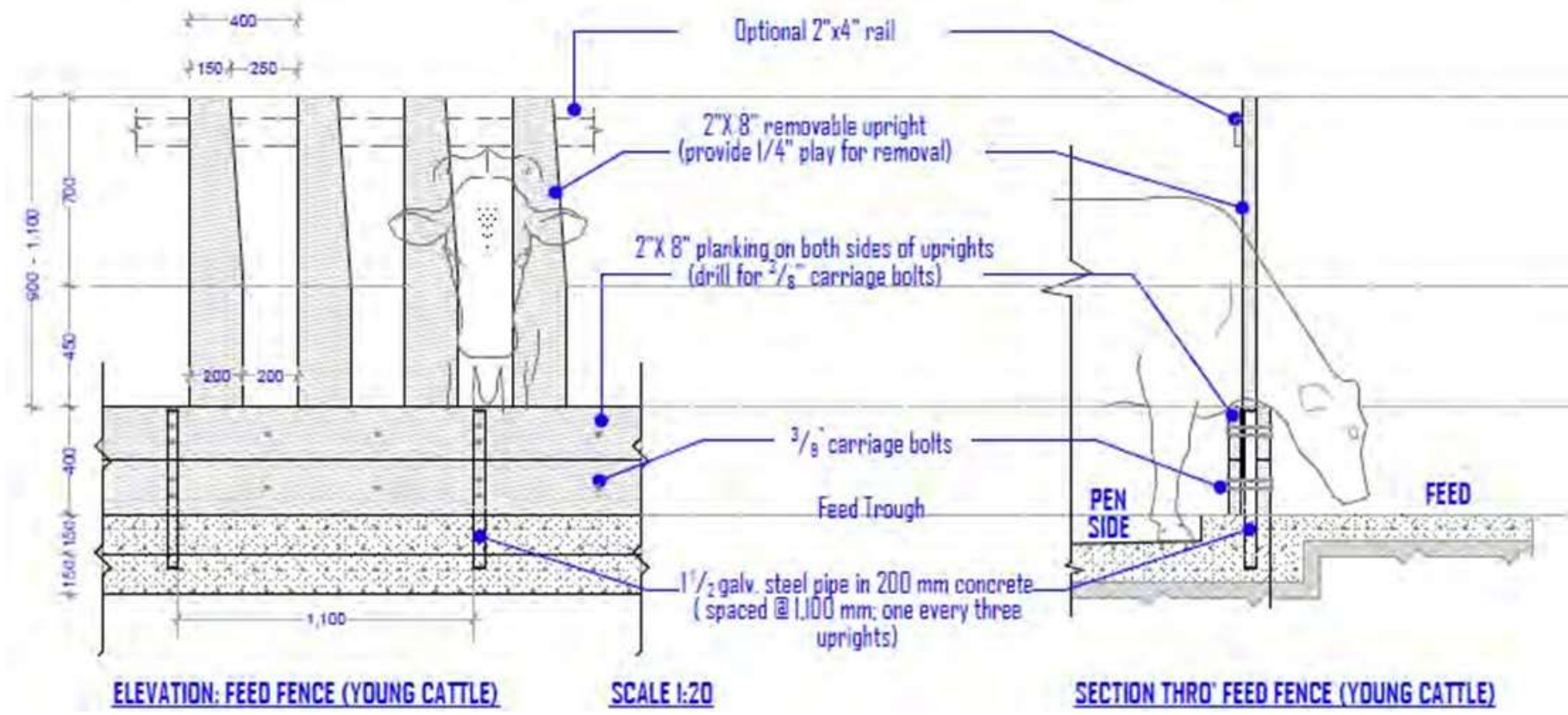

*measurements are in millimeters

7.1. Swedish feed fence design materials (Wood & steel)

- The Swedish feed fence can generally accommodate young stock and cows with horns, ensuring they can eat without hindrance.
- In the pictures on the right the dividers of the feed fence are made of solid wood and galvanized steel.
- Neck opening for the young stock category is 20 cm and for mature cows 35cm (shown in the example of the drawing below) just allowing the head and neck through the fence.



7.2. Swedish feed fence design materials (Wood & steel). Cont'd...

- The image shows the measurement (measurements are in millimeters) of the Swedish made of steel pipes (size of the pipes are in inches).

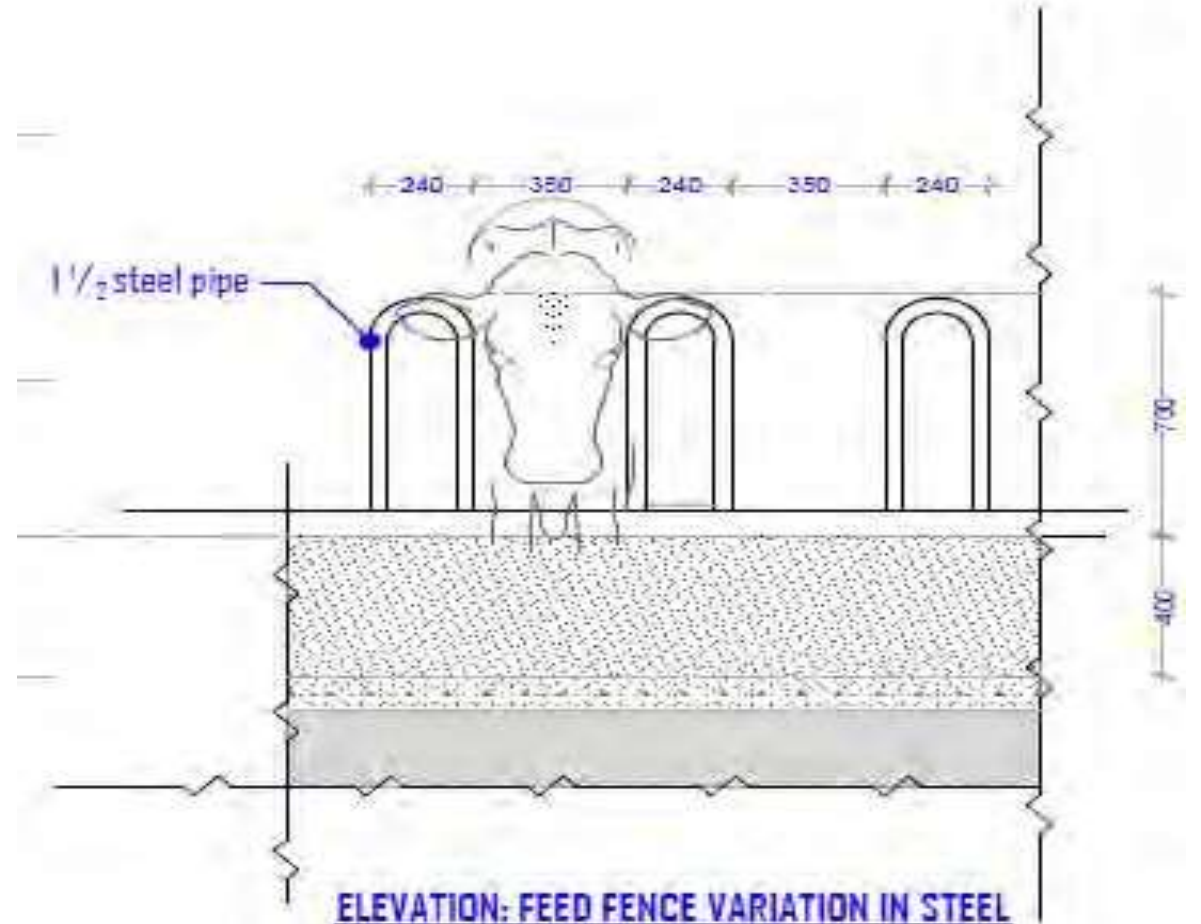

*measurements are in millimeters

8. Diagonal feed fence

- The feed fence is made of steel (galvanized steel) in a diagonal Z shape which is designed to reduce bullying, stop cattle pulling in feeds and minimise feed wastage.
- The fence has a neck rail that prevents the cows from moving away fast (for example, when they are bullied/pushed, or when they are scared) and carrying food in the walking alley.
- Therefore the feed wastage is minimised compared to the Swedish feed fence design which doesn't have the neck rails.
- The diagonal feed fences can be are designed for all cow breeds and sizes.
- This design is also known to be easy to design and cost-friendly.



9. Head (self) locking feed fence

- A (self) head-locking feed fence is used to secure cows and avoid cows disturbing each other while feeding due to differences in the social order within the herd.
- An added advantage of the (self) head locking feed fence can be to fixate cows for examination, and insemination.
- When the cows go into this type of feed fence the manager has the possibility to restrain (self-locking) them or to use the fence such that the cows can release themselves again.
-
- The feed fence has a neck rail and post-and-rail barrier that locks.
- Also this type of feed fence should be adapted to the size (breed) of the cows.



9.1. Head (self) locking feed fence. Cont'd...

- A (self) head-locking feed fence maybe be a good investment on farms with 40 or more cows, it reduces time to restrain cows and it facilitates the handling and feeding of different categories/groups of cows.
- On farms with fewer cows the benefits are less. From an economic point of view, farmers with less than 40 cows are advised to choose a different type of feed fence.



9.2. Benefits of Head locking feed fence

- Allows monitoring of feed intake for all the cows,
- Allows safe and easy handling of cows,
- Reduces incidences of bullying at the feed fence,
- Head width can be adjusted to suit different sizes of cows,
- All the cows can be released at the same time,
- Allows farmers to work safely with all types of cows.



10. Tie-stall feed fence

- The tie-stall feed fence design is known to restrain the cows in one cubicle where the cows eat and rest on the same cubicle.
- The advantage of this type of setup is that you can monitor the cows' intake throughout the day because she doesn't leave the cubicle.
- However this type of feeding system is the least comfortable of all the feed fences discussed since the cows are restrained and cannot exercise at will.



11. Feed fence dimension

- The feed fence has the following parts, it is advised to use the recommended dimensions of your cows.
- The dimensions to be considered when designing a feed fence are;
 - The fence height, the height, and position of the neck rail position(see image on the right). The orange height and the red dot is the position.
 - The cows' throat height, feed fence wall (barrier wall) (the blue height).
 - The shoulders size, and space from one cow to another (see image next slides).

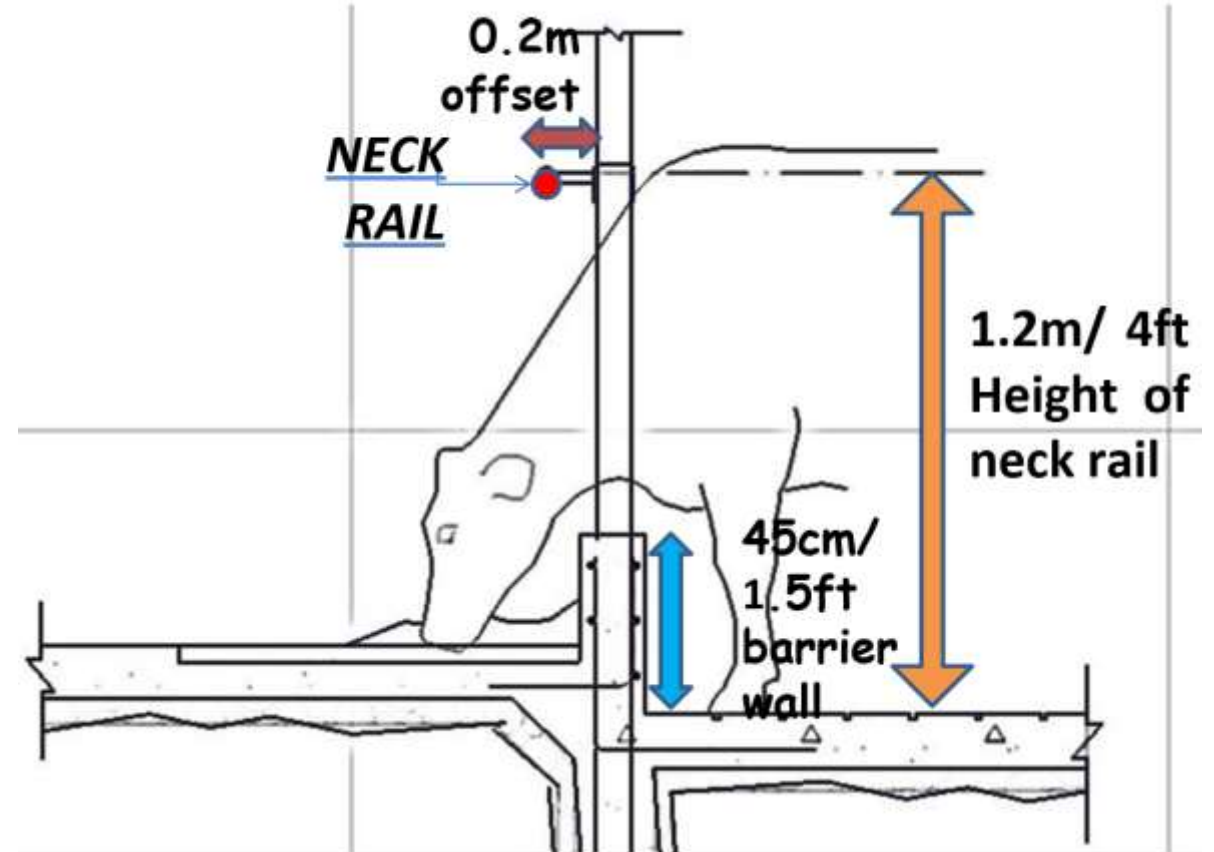

12. Neck rail and cow's height

- Restrictive neck rails prevent natural behaviors and cause injury.
- Neck lumps(as shown in the picture on the right) can occur as a result of neck rail placing pressure on a hard body part.
- The neck rail on a feed fence should ideally be 5 cm (2 ins) above the wither height (red box) of the largest cow.
- The pictures on the right shows the position of the neck rail being too low causing neck lumps.

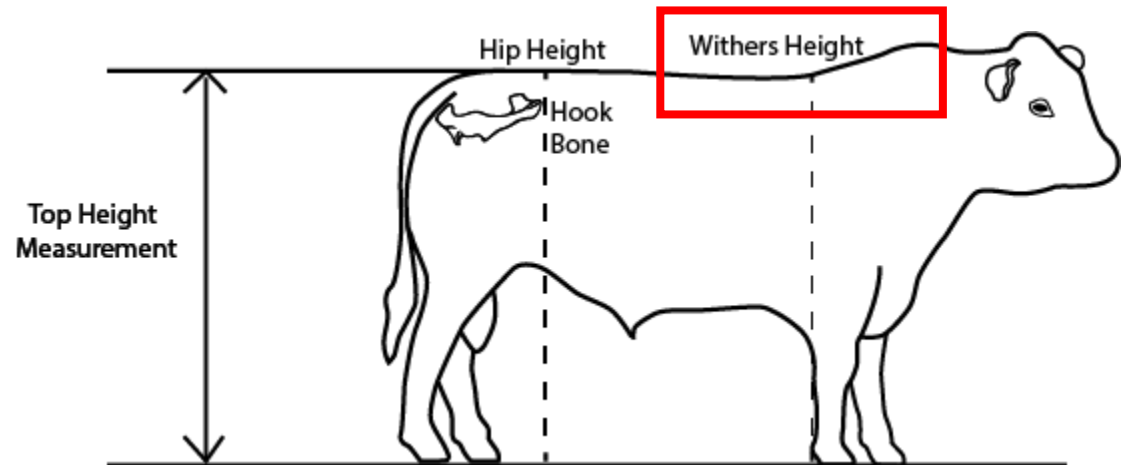

12.1. Neck rail injuries and shiny bars

- When neck injuries are observed this is not a good indication.
- When the neck rail shows shiny steel bar or wood that has been rubbed intensely this is an indication that the cows are often pressing up against the neck rail and they may be too restricted by the feed fence.
- This could cause a bare pressure patch, which is a sign of discomfort. Hence the wound on the neck rail area of the cow is a clear sign that the bars are too low and feeds on the feed table are not accessible.
- The height of the feed fence wall should also be considered and lowered if it is too high and causing hair loss and injuries at the throat skin of the cows.

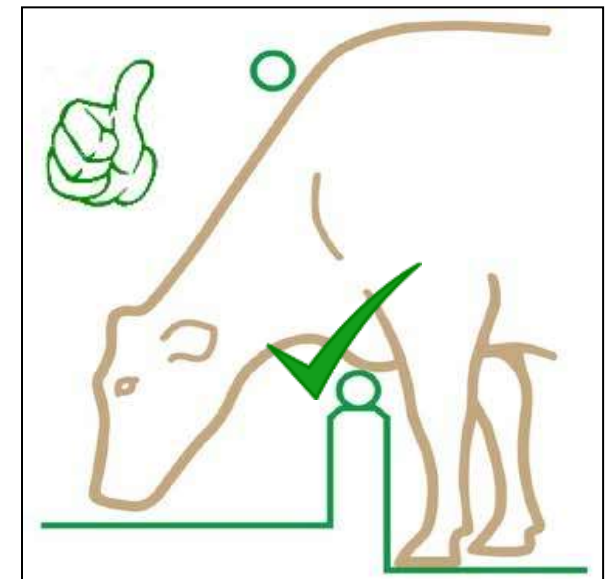
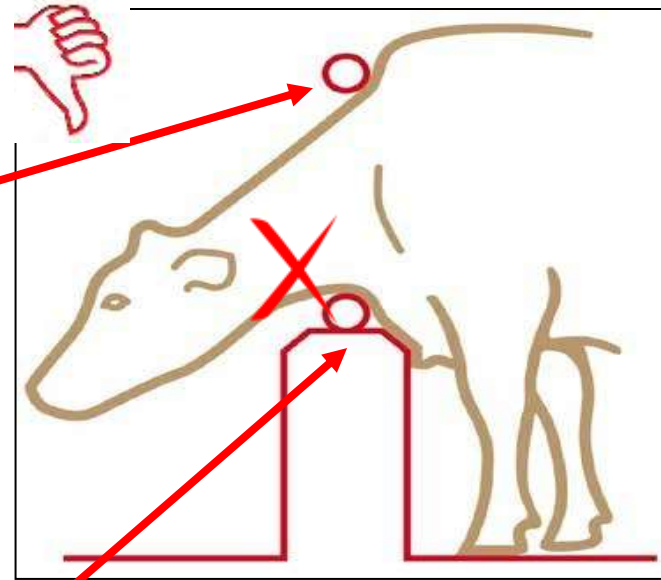

13. Space per cow

- The shoulder barrier prevents the cow from stretching further on the feed table and stepping in the feeds.
- The shoulder length of the cows determines the space per cow.
- 75cm/750mm shoulder dimension is used to space the cows in the feed fence.

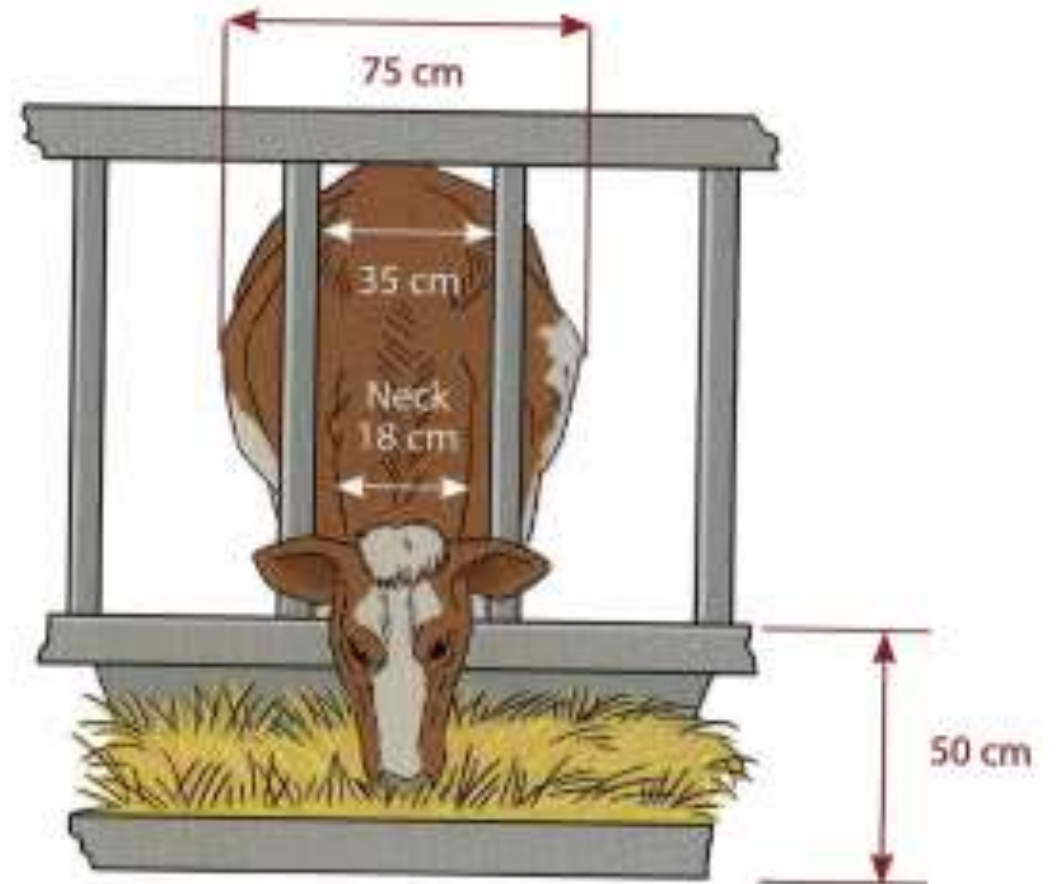

14. The shoulder barrier dimensions

- The size between the two bars is estimated to be 35cm for most mature cows.
- This size only allows the head and the neck of the cow to pass through and stops at the shoulders.
- Often in the case when the head opening of the feed fence is too narrow, cows will have bald patches and thickened neck skin.
- The width of the neck of the Holstein Friesian adult cow ranges from 18cm to 22cm.



15. Shoulder injuries

- Shoulder injuries cause when the cows push against the two bars while trying to reach the feeds on the feed table.
- The feeds should always be accessible to avoid this type of injury (the red circle shows the shoulder area where injuries occur).
- For feed alleys, the feed needs to be pushed up regularly especially when the cows are feeding.
- For feed troughs, the trough should be closer to the feed fence wall and of the recommended depth, width to assure that the size meets the requirements of the type of cow (breed) and the cow has easy access to the feeds at all times.



16. Neck rail offset

- When the neck rail and shoulder barrier are moved forward a little bit making the barrier to lean diagonally it will remove the obstruction for the cow while feeding and will prevent injuries.
- The distance from the main supporting post is 20cm/0.2m.

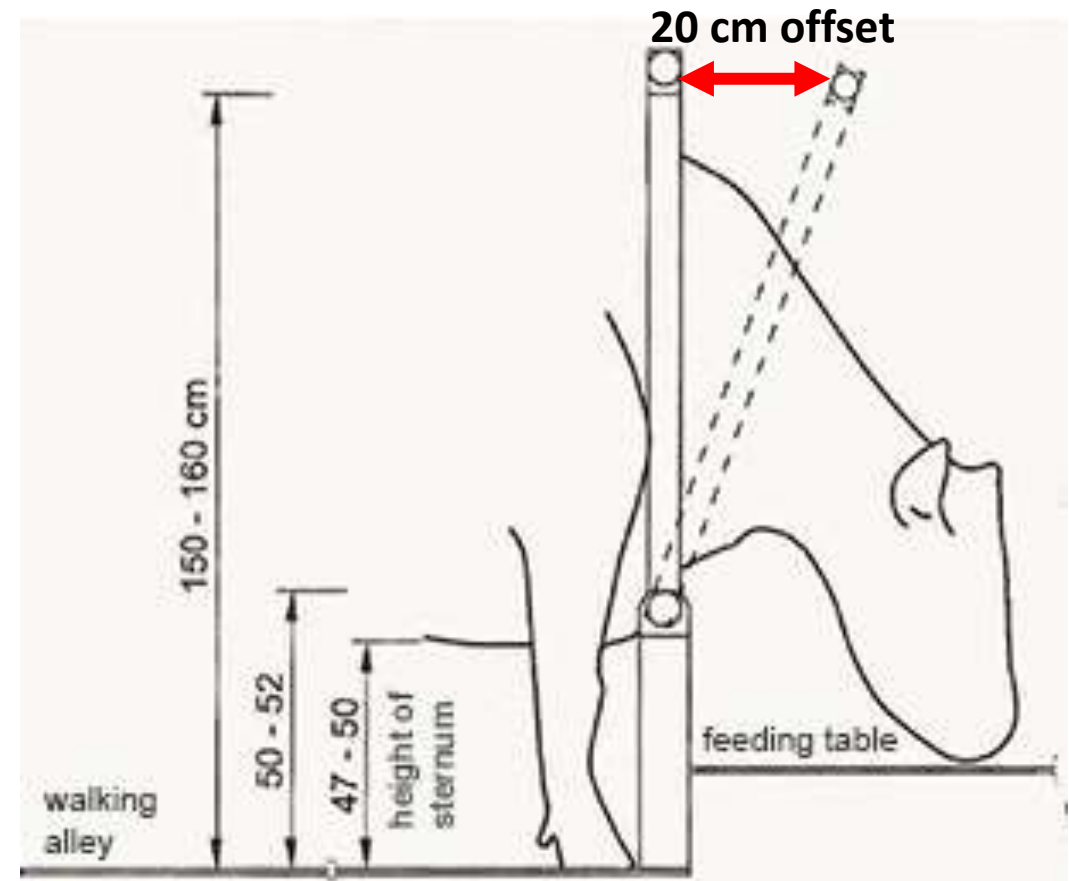

*measurements are in centimeters

17. The feed tables and troughs

- The feed table is a section of the cow barn where feeds are placed and accessible for the cows at all times.
- There are different types of feed tables;
 - Feed alley
 - Feed trough



18. Feed alley

- This area consists of the feed table and the farmer's movement area when feeding the cows or temporary store feeds for the cows.
- The feed area and feed tables should be sheltered from sun and rain, as this is not only more comfortable for the cow and the farmer but also protects the feeds from spoiling rapidly.
- The feed alley has the following characteristics.
 - Has no walls apart from the barrier wall to avoid spill over to the walking alley on one side of the feed table.
 - The floor of the feeding alley is 10-20cm higher than the walking alley where the cows are standing while eating.
 - The feed alley can be constructed with concrete floors.
 - It is easy to clean and labor-intensive.



18.1. Management of feed alley; Feed push up method

- The feed alley is easy to manage because it has no barriers and feed can be managed by a method called feed push up.
- Feed, pushed up ensures that the feed is easily accessible to the cow and the table should not be empty at any time because this will cause cows to stretch unnecessarily to access the feeds and by doing so press hard against the feed fence with neck and shoulders.
- Without proper management the cows may end up not eating enough per day.
- Push up the feed 5 to 8 times per day. Check regularly there is enough feeds and the cow can reach it without difficulty.



18.2. Cleaning of feed table and troughs

- Managing the cleanliness of feed tables is crucial. The feed table or trough should be cleaned daily.
- Spoilt feed or feed residues will result in mould growth and increase the risk of feed 'heating up' which will reduce palatability, nutritive value and limit feed intake.
- Therefore, it is important to keep feed tables and feed troughs clean at all times.



19. Feed troughs

- Cows graze with their heads positioned downwards.
- It is recommended to allow cows to feed in their natural position.
- For farmers who choose to construct a feeding trough they should consider the following;
 - Making sure the feed trough is not too high. This will result in less chewing and less saliva to be produced.
 - Very high feed troughs discourage the cow to eat enough(reduce feed intake).
 - The material used to make the feed troughs should be smooth finished concrete or hard plastic drums. To avoid acids from the feeds and minerals that cause erosion of the construction material.



19.1. Feed troughs management

- The farmer should always clean the feed troughs daily by removing all the left overs and replacing with fresh feeds.
- The feed trough should be cleaned with water (once a week) to remove the feeds residues such as dairy meal that got stuck and accumulated on the surface.
- The disadvantages of feed troughs compared with feed table;
 - Feeds tend to heat up faster than on the feed table.
 - The feed trough is more labour intensive by removing feed leftovers, cleaning and replacing feeds.



20. Cow walking/standing alley during feeding

- The standing area is the section just next to the feed fence on the other side of the feed table that accommodates the cow during feeding.
- The standing area is recommended to be constructed using concrete floors. Concrete floors allow easy cleaning and the area can be maintained dry by removing the manure daily.
- The walking/standing alley needs to be the length of one cow and allow two cows to be able to pass behind her at the same time.
- The concrete floor of the walking alley needs to be slightly sloping away from the barrier wall.
- The cow alley is recommended to be constructed 10-20cm below the feed tables.
- In the picture on the right shows how the feeding table is higher than the standing area.



21. Cow standing alley issues

- When the walking/standing alley is not of concrete maintenance and cleaning or becomes difficult.
- The area becomes dirty, wet, and muddy (as shown in the picture) making it uncomfortable and unhealthy for the cows.
- Under these conditions the cows are at risk of getting foot infections and other hoofs related diseases.
- The cows' feed intake will be reduced as well as productivity.



22. Feed fence management

- Cows should be locked in a feed fence for as short as possible because forced standing creates excessive pressure on the hooves, and thus stress and pain.
- Wrongly designed or constructed feed troughs and feed fences force the animals to perform unwanted behaviors, for example standing in the feed and contaminating it with manure.
- Cows and young stock should be able to eat in a physically optimal position, without being disturbed by barriers or obstructions.



22.1. Feed fence management. Cont'd...

- When designing and planning your building make it easy to put feed in the feed trough and to remove leftovers, because you have to do it every day two or three times. Do not make the design labour intensive even if you (but somebody else of your staff or team) are not the one having to feed the cows every day.
- All animals in a group should be able to eat at the same time, which means the feed fence needs to be long enough to accommodate all animals at the same time.
- In case of any damage to the feed fences, it should be repaired immediately to avoid injuries to the cows and further damages to the feed fence that may increase expenses further.



23. Water troughs

- A guaranteed supply of clean, good quality water is important to provide cows with their daily water requirement, for cleaning during milking and general cleaning of the facilities..
- Watering points should be easily accessible to all cows in the herd. For mature cows, the height of the water trough should not exceed 90 cm above the floor where the cow stands. A height of 60 cm is satisfactory for young stock.
- The figure below shows such a system located along the feed table.

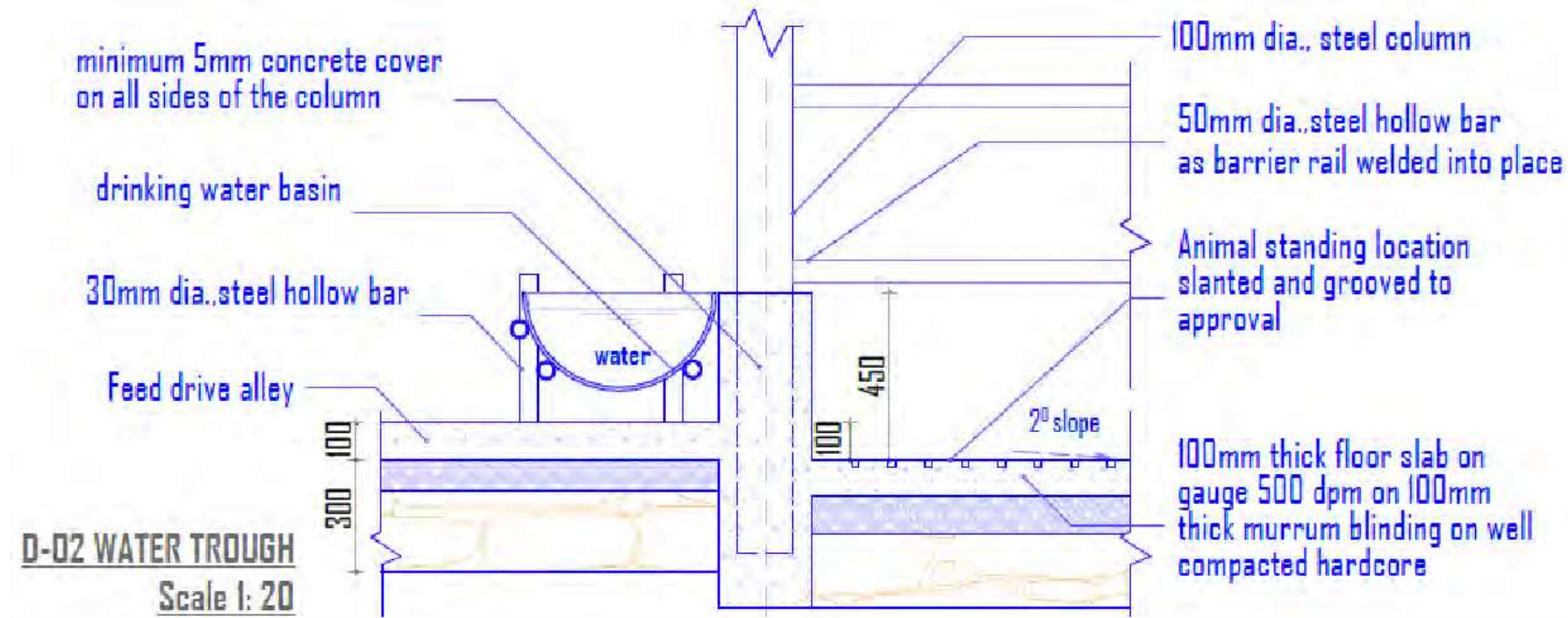

*measurements are in millimeters (mm)

23.1. Water troughs construction

- For a smallholder barn, water troughs made out of a half-cut plastic drum, supported by a steel or wooden structure, can be used as a good alternative for a permanent and more expensive concrete structure.
- Other material of making water trough can be, concrete, tiles and old bath tub.
- It is recommended to design water troughs with a water valve to maintain the water level as the valve allows the water to be replaced that has been consumed.
- The water trough should have a drainage tap at the lowest point to drain dirty water easily while cleaning.
- The pictures on the right are water troughs (from top to bottom) made of tiles and an old bathtub.



23.2. Water troughs management

- Water trough should always have fresh, clean water for the cows to drink at any time of the day and night.
- The water troughs should be cleaned daily and dirty water drained and replaced.
- Select a construction material for the water trough that has a smooth surface and is easy to clean.
- A sign that the water troughs are dirty is the accumulation of dirt on the bottom, the change in water color, growth of algae on the surface of the water or wall surface, and the reduction of water intake by cows.
- The pictures on the right show dirty water troughs and troughs made of concrete.



24. Calves, feeding troughs

- Newborns and calves before weaning (calves under 3 months old) have special feeding troughs.
- The trough can be made of different materials for example steel, wood or plastic.
- The common features are that the troughs/feeders are mostly small in size and volume.
- The picture on the right shows examples of feeders for calves to ensure that the calves have separate buckets for water, milk and feeds.



24.1. Calves, feeding troughs. Cont'd...

- The calves are fed on small amounts of feeds which are replaced daily.
- The calves are very sensitive to good hygiene and therefore the cleaning of the feeding equipment should be done daily.
- The size and the ability to remove the feeders from their position is important because it allows cleaning to be done thoroughly from the inside as well as from the outside.



25. Introducing new feed fences.

- Familiarize youngstock with a self-locking feed fence if this is what they are expected to use after calving.

