

*Theme 1: Forage production and pasture management*

# MECHANIZATION OF FEEDING MANAGEMENT (Level 3)

Topic	Training & information Content
1.1	Planning of fodder/feed requirements for the dry season
1.2.1	Integrated soil fertility management I
1.2.2	Integrated soil fertility management II
1.3	Use of natural resources, compost making, farmyard manure, manure storage and use
1.4	Growing maize and sorghum for fodder and estimating time of harvest and yield
1.5	Brachiaria, Panicum, & Napier (cut and carry) grass management
1.6	Growing fodder trees and use of feed
1.7	Estimating of dry matter content, feeding value and yield of various fodder crops
1.8	Guidelines for Tropical pasture management and grazing management
1.9	Scaled mechanization of forage production and pasture management (harvesting practices)
1.10	Operating farm equipment and self-propelled tractors
1.11	Mechanization of feeding management
1.12	Economics of forage and pasture production



## 1. You will learn about (learning objectives):

- Importance of feeding mechanization.
- Mechanizing feeding at the farm.
- The different management practices that have been mechanized e.g:
  - Frequency of feeding.
  - Delivery of feeds to cows.
  - Feed processing practices

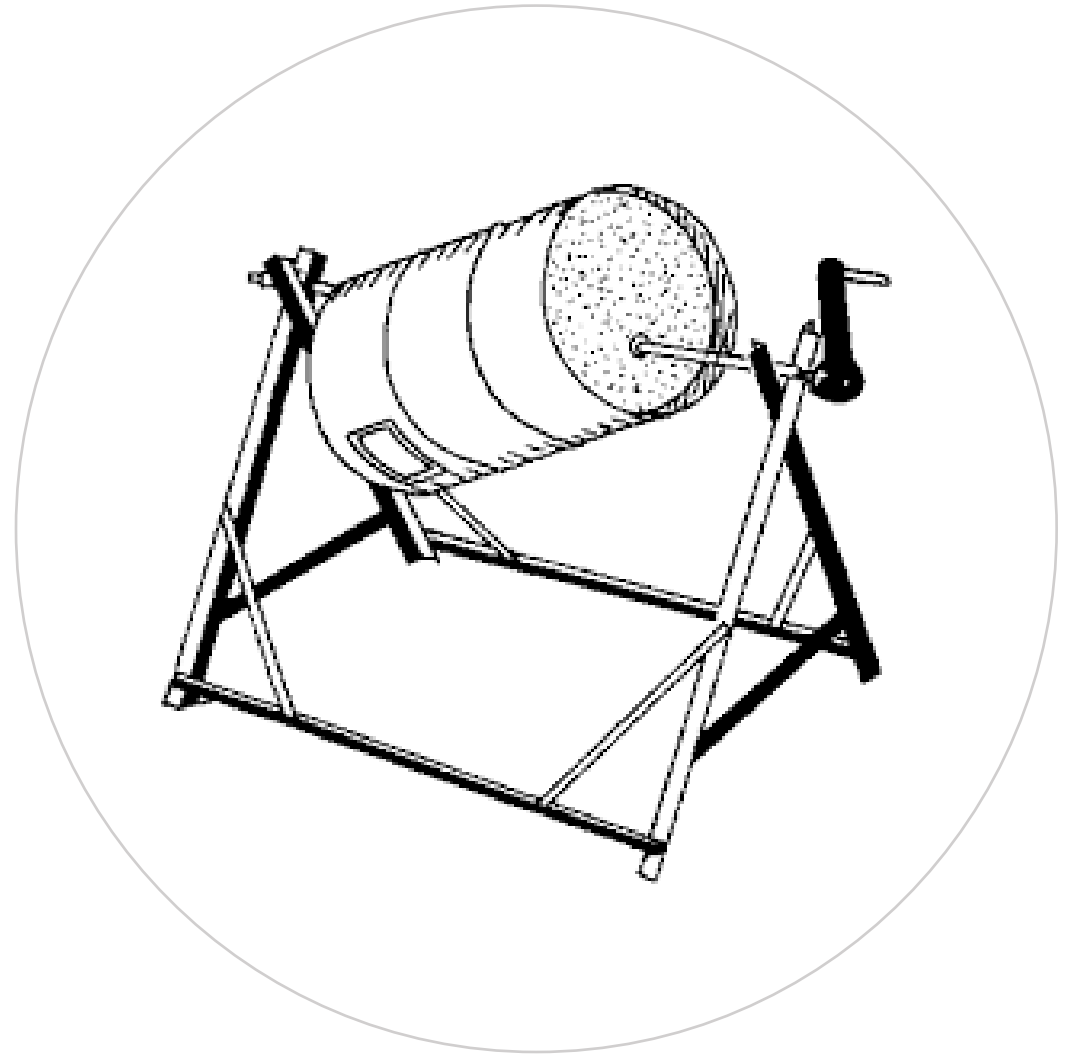

## 2. Introduction

- Feed and labour are very essential in dairy farm operations and require adequate planning and budgeting.
- Farmers should therefore choose appropriate power source depending on work to be done and who is performing it.
- Mechanization of feeding management helps reduce challenges and high costs related to feeds and manpower (labour).
- Machinery enables one to get higher output from various stages for example: planting, harvesting to feeding while meeting needs efficiently and effectively.



### 3. Benefits of feeding mechanization

- i. Lowers operating costs.
- ii. Saves on resources e.g. time used in doing the activity and raises the efficiency of labour.
- iii. Increases production output e.g. feed quality.
- iv. Ensures consistency, improved and quality feed management.
- v. Encourages better feed planning strategies.
- vi. Improves productivity and efficiency of feed management.



## 4. Areas for mechanization in a farm

- It is important to make dairy activities easy to facilitate better animal rearing and production.
- Farms can adopt mechanization in various areas of operation for example:
  - i. Feeding related areas/zones
    - Feed production
    - Animal feeding
  - ii. Milking and milk handling
  - iii. Manure collection
- All these activities are done to keep the animal healthy and ensure continued milk production.



## 5. Feeding related area: Animal feeding

- Some of the equipment and/or techniques used in a feeding area include:
  - Feeding frequency
  - Feed delivery: feed bunk/trough
  - Management of pastures
  - Feed barriers
  - Watering system (pumps and troughs)
  - Feed processing: Feed mixer
  - Monitoring and evaluation of feeding (transponders)



## 6. Feeding frequency

- Frequent delivery of feeds is an important strategy in dairy farm management.
- Feed placement and handling can take place averagely three (3) times a day. This contributes to feeding throughout/most times of the day and also at night.
- Increasing feeding frequency (2×) is found to increase the time animal spends feeding in a day.
- Feeding once a day often results in sorting of feed and unequal access to feed by cows. Feeding frequently helps solve these problems.



## 6.1 Importance of feeding frequently

- i. Gives the rumen microbes adequate time to adjust to ingredient changes in a whole ration.
- ii. Maintains good rumen health and rumen pH within normal levels (5.5-5.8).
- iii. Encourages more feed intake per day.
- iv. Reduces incidences of metabolic disorders like rumen acidosis (sub-acute rumen acidosis).
- v. Increases milk production as a result of increased feed intake.
- vi. Helps reduce heat production leading to reduced heat stress.
- vii. Enables better cow fertility bringing about more profits to the farm due to early age at first insemination.





## 7. Feed delivery: Feed chop size

- Chopped forages (averagely 0.8-1.2cm) improves feed intake by cows.
- Farmers can chop forages using a panga, chaff cutter or chopper that is manually or mechanically driven by a tractor in the field. (Roller) mills also crush grains.
- The use of a chopper that can chop forages and grind grains (in a different compartment) is great 2 in 1 machinery to farmers.
- Mixers also help reduce particle size of feed ingredients as mixing is done.

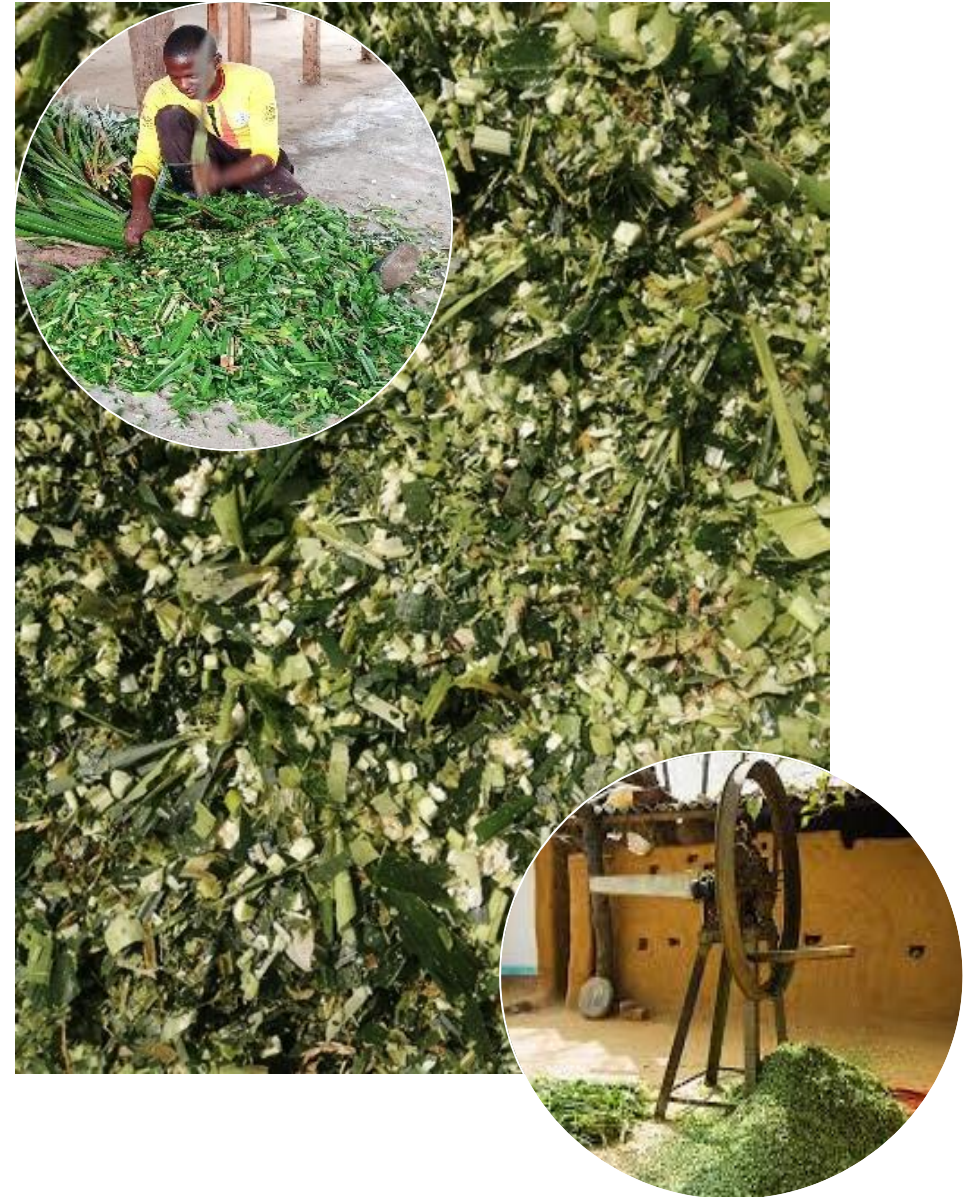

## 8. Feed delivery: Feed bunk/trough

- Feed delivery using feed bunk/trough aids better feeding through better feed access.
- Bunks may be made of wood, iron or cement.
- Feeds are placed on the bunk according to animal requirements.
- Feed bunk /trough reduces losses caused by cows trampling on feed when fed on the ground.



## 8.1 Feed management within the feed bunk/trough

- Ensure the feed bunk is clean. Clean feed bunk equals clean feed.
- Clear the feed bunk after feeding and where necessary combine leftover feeds with next session feed ration.
- Inspect the feed bunk incase of loose nails, holes in the bunk causing feed losses.
- Be purposeful when selecting site for the feed bunk and consider rainy seasons. Ensure the area is shaded to protect feeds inside the feed bunk from being rained on.
- Turn feeds in the feed bunk especially fermented feeds (silage) to avoid heating up.



## 9. Management of pastures

- Good management practices and planning of pastures ensure long productive cycle of fields. This yield quantity & quality forage adequate to meet nutritional need of cows.
- The use of fences like barbed wire or electric fences helps a lot in segmenting pasture fields.
- Use of special gate (creep gate) to give priority to special group of animals ahead of other cows in a pasture field is another mechanized pasture management practice.
- Segmented pasture fields makes it easy to practice rotational grazing. This helps to better manage the growth and utilization of pastures.
- Cutting grass to a uniform level helps improve overall growth compared to leaving grass that is unevenly grazed to grow back.



**Further reference:** Modules on Feeding systems and Guidelines for tropical pasture management.

## 10. Feed barriers/fences/neck rail

- These are mostly used by farmers practicing intensive feeding systems (zero grazing).
- These structures are incorporated with the cow house/barn.
- Movable barriers are placed in line in a parallel way, in such a way that cows can pass their heads through it to access feeds.
- Feeds are mechanically pushed using a shovel/brush nearer to the cows after a while due to the constant pushing of feeds as cows select the feeds in the feeding area.
- Adequate space should be left in front of the feed barrier to enable the movement of tractor drawn implements that can deliver feeds to the feed area (feed barrier).



## 11. Watering system

- Water is an essential need for cows. Cows consume large volumes of water per day, which is influenced by the individual cow demands and environmental conditions.
- Water delivery/supply to watering points is a challenge especially if from natural water sources such as streams, river and even wells.
- Mechanisation of the watering system can be done from the initial delivery of water to the mode they access the water.
- Systems of key importance in feeding (water) management are for example:
  - i. Water delivery (pump)
  - ii. Water access (water troughs)

**Further reference:** Module on Water sources, distribution, storage and requirements.



## 12. Watering pumps

- Delivering water from their sources to the farm is sometimes challenging and time consuming.
- A common method of water delivery in Uganda is the use of rope and bucket to get water from underground water sources. This method can be tedious, limiting water access to cows.
- Use of gravity or pressure helps reduce the hustle of cows going to the source or having to wait for water delivery for longer time periods. It also helps farmers concentrate on other management issues in the farm.
- Use of solar pumps is gaining momentum and is solving water delivery challenges to farm watering points at low cost.

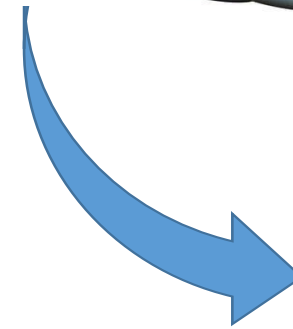

**Further reference:** Module on Water sources, distribution, storage and requirements.

### 13. Watering system: Water troughs

- Mechanisation has aided the efficiency with which cows freely access clean water while preventing overflows.
- This is by use of automatic water valves in tubs and water trough-like structures, which reduces efforts in supplying water into water troughs.
- When the ball floats near the top of the trough, the lever holds the inlet valve closed to prevent water from entering the trough.
- As the level drop as cow drink water the ball sinks and causes the lever to tilt and allow the inlet valve to open and water flows into the trough until the ball gets to the top again.

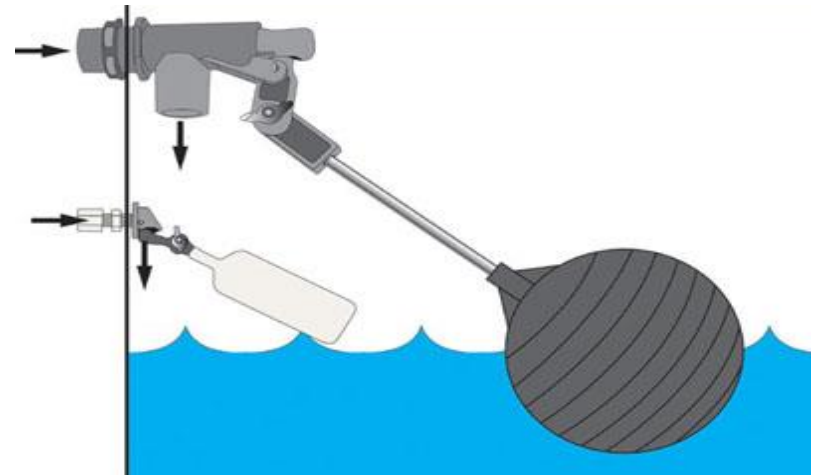
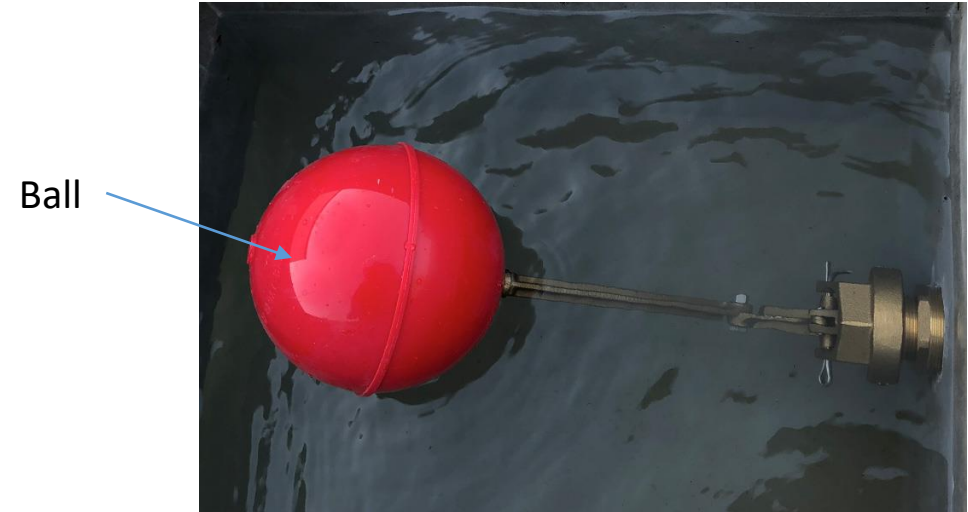



## 14. Feed mixing

- Cows are naturally selective feeders, mainly affected by smell and the feel of feeds (soft or rough forage).
- Mixing of forage with processed feed ensures homogenous mixed rations to avoid feed selection, such that each bite contains all ingredients.
- Feed mixing has undergone many changes and development over the years making it easier and manageable.
- Mixing is an important step of feed processing. It involves use of hand mixing, use of shovel, wheelbarrows and feed mixers (manual drum mixers or mechanized feed mixers).



## 15. Feed mixing by hand

- Hand mixing is commonly practiced by smallholder farmers.
- Premixing is done by hand in large containers or wheelbarrows.
- Mixing of small quantities of feeds require mixing by hand. For example during making few mineral block or molasses urea mineral blocks. Some farmers are also used to mixing feeds while in the feed trough before cows eat.
- Hand mixing is also practiced when left overs are to be mixed with new feed, to reduce selectiveness of cows to feeds.
- Cows are very selective especially when they smell the saliva of another cow in feeds, this is common for cows sharing a feed bunk/trough.



## 16. Feed mixing by shovel

- This is also a common method of mixing feed ingredients in farms and has greater output compared to hand mixing.
- Shovel mixing are used on medium to larger farms and also for pushing feed towards the feeding barriers for cows.
- Mixing can be done on the ground or inside a wheelbarrow.
- Mixing on the ground is usually placed in bags or mixed then transported to feeding area.
- Shovel mixing on the wheelbarrow aids direct delivery to the cow feeding area.



## 17. Feed mixing by manual drum mixer

- The manual drum mixer is an improvement from the manual mixing using hands/shovels.
- It is an equipment that is used for mixing feed ingredients in a particular ratios by manually turning the drum to mix feed ingredients inside.
- The drum mixer is made of a drum fitted with metallic fork-like projections inside the drum to facilitate mixing, with an opening on the side for placing of ingredients.
- Used to create small portion of feeds and is recommended for farmers with small herd sizes (<10).

Watch video:

[https://www.youtube.com/watch?v=LvyvbSLJ\\_V0](https://www.youtube.com/watch?v=LvyvbSLJ_V0)

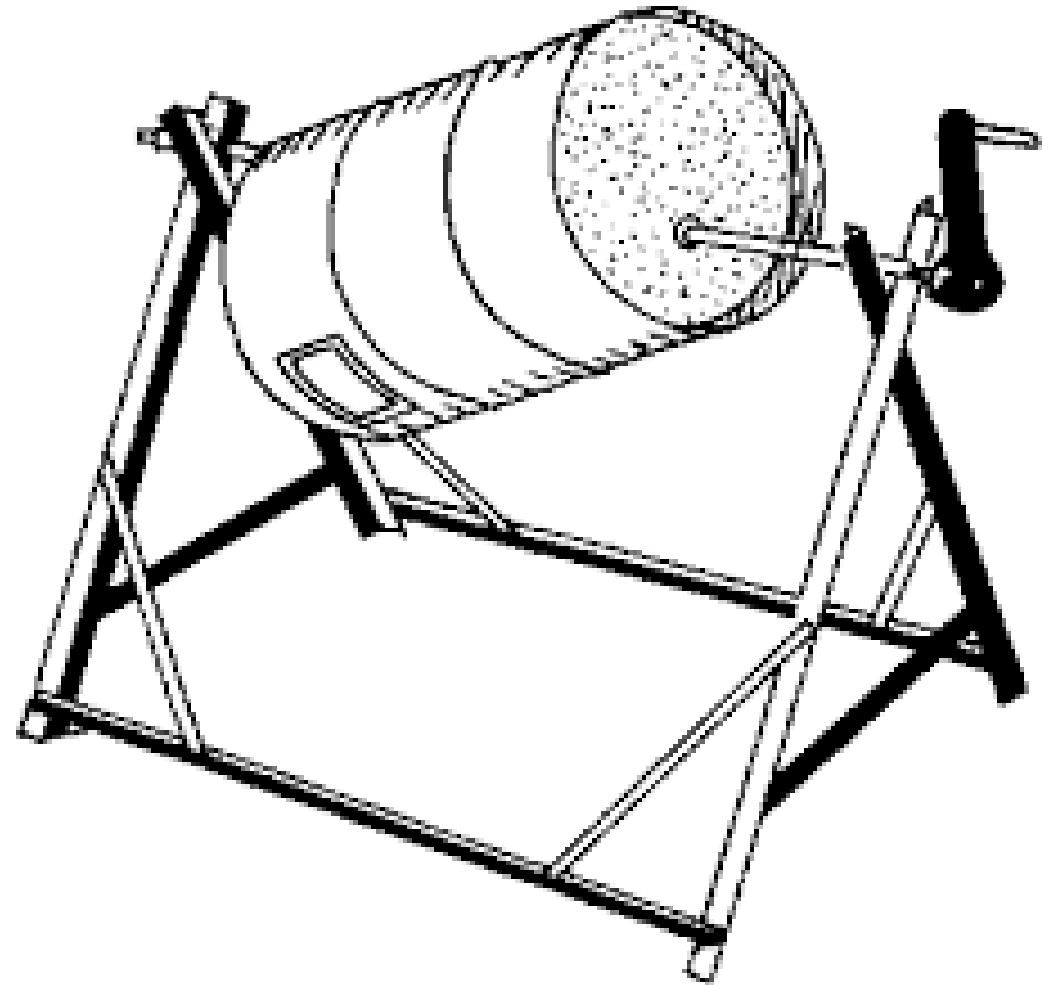

## 18. Feed mixing by feed mixer

- Feed mixers are generally used to combine/mix different ingredients to achieve a homogenous/uniform product.
- Feed mixers in dairy farms can either be manual or mechanically driven. Mixers help create total mixed ration (TMR).
- There are two common types of mixers that farmers can choose from, that is:
  - i. Manual drum mixer
  - ii. TMR mixer
- Mixer should allow variety of feeds to be blended. Mixing of feed should consider:
  - Proper weighing.
  - Accurate formulations.



## 19. TMR mixer

- A TMR mixer is an equipment used for mixing feed ingredients and formulated to a specific nutrient concentration.
- All feed ingredients are blended together homogenously. Mixing causes the motion of particles. The mechanical movement of particles is done using augers, reels, chains and drums.
- Some mixers have knife sections enabling them to cut/chop long, dry hay.
- TMR mixer is operated automatically through the press of a button, this facilitate large volume production. This is what is mostly used by large farms and agro-industries.
- There are variety of mixer designs in the market.



## 19.1 Mixer cart

- This is a scaled down version of some other design/model of mixers.
- They are usually powered by a gas engine.
- This kind of mixer is used for small volumes of feeds, for example: mixing can produce feeds to feed 12-24 cows per batch mixed.
- This is commonly used and is affordable to farmers.



## 20. Types of TMR mixers

- There are many different mixer designs in the market and they are categorized under either:
  - i. Horizontal mixer
  - ii. Vertical mixer

Paddle feed mixer



Horizontal auger feed mixer



Reel feed mixer



Tumble feed mixer



Ribbon feed mixer



Vertical auger feed mixer

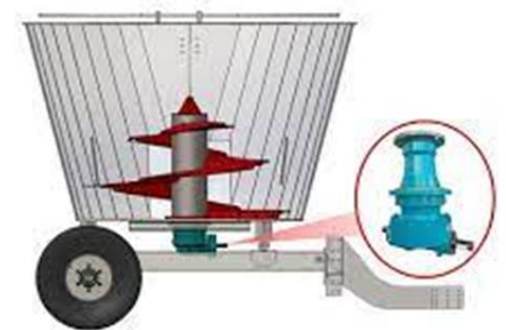



## 20.1 Horizontal vs Vertical mixers

- Horizontal mixers are more efficient for liquid ingredients like molasses. They also handle silage and ground hays better while vertical mixers are better for whole round hay bales and baled silage.
- Horizontal mixers use less mixing time.
- Horizontal mixers have higher energy cost.
- Horizontal mixers are more expensive.



Horizontal  
mixer

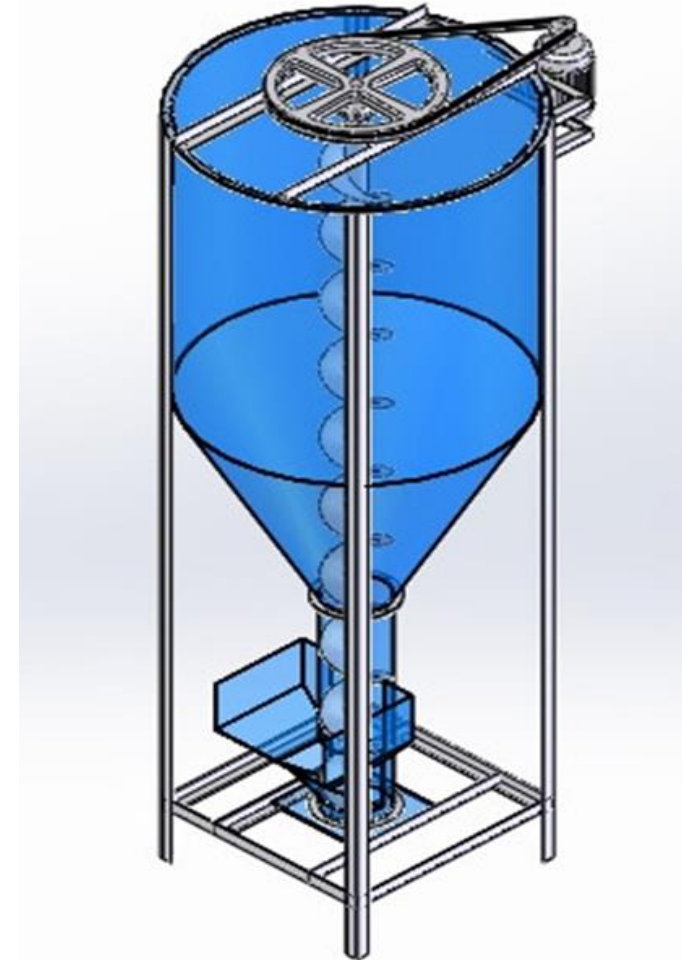

Vertical mixer

## 21. Mixing ingredients

- The goal of mixing ingredients e.g. using tumble action (reel mixer) is to create a homogenous rations.
- As particles move, feed ingredients get to be reduced which is desirable but can also reduce roughage value. This is why it is important to review the recommendations of the manufacturer on adding ingredients into the mixer.
- Mixers vary in ingredient flow and in the aggressiveness of the action. Avoid dumping all the ingredients into the mixer randomly.



## 21.1 Factors affecting mixing outcomes

- i. Type of mixer chosen - Auger and reel mixer models are better for rations with chopped silages and limited hay.
- ii. Condition of the mixer - Influenced by cleanliness, sharpness of blades and wear & tear of equipment.
- iii. Under filling or over filling of the mixer - Underfilling does not enable even mixing and overfilling causes some particles to stay at the top preventing even mixing. Fill the mixer to about 85% gives better results.
- iv. Length of mixing the ingredients - Longer mixing time causes over mixing making outcome to be too fine while short mixing time causes under mixing of ingredients.

Worn Augers



## 21.2 Factors affecting mixing outcomes Cont'd...

- v. Ingredient particle size - Large particles require longer period for mixing; it may be hard to get an even mix outcome compared to smaller sized particles.
- vi. Hay quality & processing - Round bales will take longer period to be mixed.
- vii. Density of the ingredients - For example viscous/thick liquids (molasses).
- viii. Ingredient mix order can - Different model require different ingredient mix order for best outcomes.



## 22. Adding feeds to a TMR mixer

- Add feeds in the following order when using an auger mixer:
  - i. Concentrates and other grains
  - ii. Ensiled forages (maize silage)
  - iii. Dry forages, chop for best results
- Add feeds in the following order when using a vertical mixer:
  - i. Dry forages
  - ii. Grains
  - iii. Concentrates
  - iv. Ensiled forages (maize silage)



## 23. Advantages of a TMR mixer

- It accomplishes TMR feeding through consistent feed ration/same mix in the same amount at the same time.
- Enables accurate formulation of feed ration.
- Encourages proper feed intake of all ingredients.
- Has better feed efficiency.
- Separated feed rations can be made for different cow grouping, which ensures all cows feed requirements are met.
- Non-protein nitrogen sources like urea and unpalatable feed ingredients can be included in the ration.



## 24. Automization of feeding management

- Monitoring and evaluation of feeding management is the future of dairy farming through the use of transponders.
- Transponder are tag-like objects placed on individual cows which collects signals and automatically transmits a different signal.
- Animal feeding is not a very easy as it sounds but with new technology it can be done with touch of a button.
- The new technology monitors animal behavior in all aspects and facilitates easy recording of information.
- It keeps track of the cows position, walking, standing, lying, rumination and other (active & inactive) activities within the day.
- This data is then translated into information about health, fertility, nutritional status and well-being of individual cows.

